

JAVIER  
ALBORNOZ

MUSIC  
COMPOSITION  
AND  
PRODUCTION  
FOR  
MEDIA

 EDITORA  
ARTEMIS

JAVIER  
ALBORNOZ

MUSIC  
COMPOSITION  
AND  
PRODUCTION  
FOR  
MEDIA

 EDITORA  
ARTEMIS

*2020 by Editora Artemis*  
Copyright © Editora Artemis  
Copyright do Texto © 2020 O autor  
Copyright da Edição © 2020 Editora Artemis  
**Editora Chefe:** Prof<sup>a</sup> Dr<sup>a</sup> Antonella Carvalho de Oliveira  
**Diagramação:** Helber Pagani de Souza  
**Edição de Arte:** Renato Rodrigues da Cruz  
**Revisão:** O autor



Todo o conteúdo deste livro está licenciado sob uma Licença de Atribuição *Creative Commons*. Atribuição 4.0 Internacional (CC BY 4.0).

O conteúdo dos artigos e seus dados em sua forma, correção e confiabilidade são de responsabilidade exclusiva dos autores. Permitido o download da obra e o compartilhamento desde que sejam atribuídos créditos aos autores, mas sem a possibilidade de alterá-la de nenhuma forma ou utilizá-la para fins comerciais.

### Conselho Editorial

Prof.<sup>a</sup> Dr.<sup>a</sup> Iara Lúcia Tescarollo, Universidade São Francisco (USF)  
Prof. Me. Javier Albornoz, University of Miami and Miami Dade College  
Prof.<sup>a</sup> Dr.<sup>a</sup> Livia do Carmo, Universidade Federal de Goiás  
Prof.<sup>a</sup> Dr.<sup>a</sup> Vanessa Bordin Vieira, Universidade Federal de Campina Grande

<b>Cataloging-In-Publication (CIP) (eDOC BRASIL)</b>	
A339m	Albornoz, Javier, 1982-. Music composition and production for media [electronic resource] / Javier Albornoz. – Curitiba, Brazil: Artemis, 2020.  Format: PDF System requirements: Adobe Acrobat Reader Access mode: World Wide Web Includes bibliography ISBN 978-65-81701-02-4 DOI: 10.37572/EdArt_024110220  1. Composition (Music). I. Title.  DDC 781.61
<b>Prepared by Maurício Amormino Júnior – CRB6/2422</b>	

Editora Artemis  
Curitiba - Paraná - Brasil  
[www.editoraartemis.com.br](http://www.editoraartemis.com.br)  
artemis@editoraartemis.com.br



## LIST OF FIGURES

<b>CHAPTER I .....</b>	<b>11</b>
FIGURE 1.1 – MOTIF A - VIOLIN SOLO, MEASURES 3 – 6 .....	12
FIGURE 1.2 – MOTIF A, VARIATION 1 - ENGLISH HORN*, MEASURES 5 – 8 .....	13
FIGURE 1.3 – MOTIF B - FLUTE 1, MEASURES 12 - 17 .....	13
FIGURE 1.4 – START OF SECTION B - CLARINET SOLO, MEASURES 32 – 33.....	14
FIGURE 1.5 – SECTION B, MOTIF C, VLN. 1 AND COUNTERMELODY (OBOE, EN. HN., AND BSN. I), MS. 48 – 51 .....	14
FIGURE 1.6 – MOTIF A, VARIATION – FRENCH HORN SOLO, MEASURES 55 – 59.....	15
FIGURE 1.7 – ACCOMPANIMENT EXAMPLE, BASSOON 2, MEASURES 64 – 65 .....	15
FIGURE 1.8 – CLARINET COUNTER MELODY, MEASURES 64 – 69 .....	15
FIGURE 1.9 – FLUTE 1 AND 2, MEASURES 70 – 71 .....	15
FIGURE 1.10 – WOODWINDS – SECTION A TO B TRANSITION, MEASURES 72 – 77 .....	16
FIGURE 1.11 – WHOLE TONE SCALE TRANSITION, VLN. 1 – MEASURES 75 – 77 .....	16
FIGURE 1.12 – MOTIF A (VARIATION), VIOLIN 1, 2 AND VIOLAS, MEASURES 80 – 83.....	17
FIGURE 1.13 – MOTIF C (VARIATION), VIOLIN 1 AND 2 (NOT SHOWN), MEASURES 87 – 91 .....	17
FIGURE 1.14 – TROMBONE 3 AND TUBA, STRINGS, PERCUSSION – MEASURES. 97 - 100 .....	18
FIGURE 1.15 – FRENCH HORNS 1 AND 2 – MOTIF A (VARIATION) – MEASURES. 97 - 100	18
FIGURE 1.16 – “FURIOSO” PATTERN – 2 FLUTES AND PICCOLO - MEASURE 105 .....	18
FIGURE 1.17 – CHROMATIC PATTERN IN OBOE, ENGHN, 2 CL – MEASURES 107 – 10 ....	19
FIGURE 1.18 – 1 <sup>ST</sup> VIOLINS - MEASURES 110 – 112 .....	19
FIGURE 1.19 – TROMBONES, TUBA, PERC., AND STRINGS, FINAL STATEMENT OF MOTIF A - MEASURES 124 – 127 .....	20
FIGURE 1.20 – ACCOMPANIMENT IN STRINGS, HARP, AND VIBRAPHONE – MEASURES 1 - 6 .....	21
FIGURE 1.21 – STACCATO SECTION B ACCOMPANIMENT, FLUTES 1 AND 2 – MEASURES 36 – 37 .....	21
FIGURE 1.22 – WALTZ ACCOMPANIMENT, TROMBONES, TUBA, AND PERC. – MEASURES 78 – 79 .....	22
FIGURE 1.23 – CELLI ACCOMPANIMENT – MEASURES 78 – 79 .....	22
FIGURE 1.24 – FAST “MURMURING” ACCOMPANIMENT, VLN. 2 AND VIOLA – MEASURE 109 .....	22
FIGURE 1.25 – ACCOMPANIMENT PATTERN, FLUTES 2 AND PICCOLO – MEASURES 118 – 119 .....	23
FIGURE 1.26 – PLAY VIRTUAL INSTRUMENT – SEVERAL ARTICULATIONS LOADED.....	24
FIGURE 1.27 – KEY EDITOR – CHANGING KEY SWITCHES ON A PICCOLO PHRASE .....	25
FIGURE 1.28 – KEY EDITOR – EXPRESSION AND MODULATION IN A VIOLIN PHRASE ....	26



FIGURE 1.29 – BUSES/GROUPS, SHOWING FADERS FOR STRINGS AND HARP GROUPS.	27
FIGURE 1.30 – OBOE EQUALIZATION	28
FIGURE 1.31 – FRENCH HORN BUS COMPRESSOR	29
FIGURE 1.32 – REVERB PLUGIN, EFFECTS SEND	29
FIGURE 1.33 – DYNAMICS PROCESSING, MAIN OUTPUT	30
<b>CHAPTER II</b>	<b>32</b>
FIGURE 2.1 – MAIN THEME, AS PRESENTED BY BANJO I IN MX01: “OPENING TITLE”, MEASURES 3 - 6	34
FIGURE 2.2 – CUE MX01: “OPENING TITLE”, MEASURES 1 - 8	34
FIGURE 2.3 – SYNTH PAD I, MEASURES 17 – 20	35
FIGURE 2.4 – MAIN THEME, AS PRESENTED BY BANJO I IN MX07: “THE ARREST”, MEASURES 4 - 9	35
FIGURE 2.5 – MAIN THEME, AS PRESENTED BY TWO SOLO VIOLINS IN MX07: “THE ARREST”, MEASURES 22 - 26	36
FIGURE 2.6 – MAIN THEME, SOLO VIOLIN I: “THE ARREST”, MEASURES 23 - 27	38
FIGURE 2.7 – SYNTH PAD I – ABSYNTH ADSR ENVELOPES	39
FIGURE 2.8 – SYNTH PAD II – TASSMAN MODULAR EDITOR VIEW	40
FIGURE 2.9 – BANJO AND VIOLIN VST INST. CHANNEL AUXILIARY SENDS	41
<b>CHAPTER III</b>	<b>44</b>
FIGURE 3.1 – PIANO, MEASURES 1 - 4	45
FIGURE 3.2 – B SECTION MELODY, VIOLA AND CELLO SECTION DIVISI	46
FIGURE 3.3 – ENGLISH HORN I MELODY, MEASURES 9 - 15	46
FIGURE 3.4 – WOODWINDS, MEASURES 22 - 27	46
FIGURE 3.5 – ENGLISH HORN VIRTUAL INSTRUMENT PLUGIN, MAIN PANEL	47
FIGURE 3.6 – FRENCH HORN I MELODY, MIDI DATA, MEASURES 40 – END	48
FIGURE 3.7 – PIANO VIRTUAL INSTRUMENT	49
FIGURE 3.8 – GROUP, EFFECTS, AND MAIN OUTPUT CHANNELS	50
FIGURE 3.9 – ALTI REVERB PLUGIN	50
<b>CHAPTER IV</b>	<b>52</b>
FIGURE 4.1 – ACOUSTIC GUITAR, MEASURES 1 - 3	53
FIGURE 4.2 – FULL SCORE, MEASURES 5 - 8	54
FIGURE 4.3 – SOLO VIOLIN, VOICE, AND SOLO CELLO. MEASURES 9 - 12	54
FIGURE 4.4 – HARMONIC PROGRESSION, MEASURES 6 - 8	54
FIGURE 4.5 – VOICE-OVER SCRIPT	56
FIGURE 4.6 – VOCAL MICROPHONE PRE-AMPLIFIER – UNIVERSAL AUDIO 4-710D	58
FIGURE 4.7 – VOCAL MICROPHONE SETUP W/ GOBO AND POP FILTER – AKG C414	59

FIGURE 4.8 – MARKER LIST – NUENDO – VOICE-OVER SCRIPT .....	60
FIGURE 4.9 – DRUM BUS EQ - NEUTRON .....	61
FIGURE 4.10 – BASS EQ - NEUTRON.....	62
FIGURE 4.11 – LEAD VOCAL PARALLEL EQ - NEUTRON.....	63
FIGURE 4.12 – LEAD VOCAL PARALLEL COMPRESSION - NEUTRON .....	64
FIGURE 4.13 – VOICE-OVER – DIALOGUE DE-NOISE.....	65
FIGURE 4.14 – RX AUDIO EDITOR – CLICK REMOVAL.....	66
FIGURE 4.15 – VOICE-OVER DE-ESSER - NECTAR.....	67

## TABLE OF CONTENTS

<b>ABSTRACT</b> .....	<b>9</b>
<b>CHAPTER I</b> .....	<b>10</b>
1    ORCHESTRAL COMPOSITION: CARNIVAL OF SHADOWS" .....	10
1.1    INTRODUCTION.....	10
1.2    COMPOSITION ANALYSIS .....	11
1.2.1    ANALYSIS OF ORCHESTRATION, FORM, AND THEMATIC MATERIAL .....	11
1.2.2    ACCOMPANIMENT .....	19
1.3    PRODUCTION ANALYSIS .....	22
1.3.1    SEQUENCING .....	22
1.3.2    MIXING .....	25
1.4    CONCLUSION .....	30
<b>CHAPTER II</b> .....	<b>31</b>
2    OPENING CUES AND FINAL CUES FOR DRAMATIC SHORT FILM: "RANKLING" .....	31
2.1    INTRODUCTION.....	31
2.2    PLOT OVERVIEW AND SCENE DESCRIPTIONS .....	32
2.3    COMPOSITION ANALYSIS .....	32
2.3.1    CUES MX01 & MX02: "OPENING TITLE" & "THE PROPOSITION" .....	32
2.3.2    CUES MX07 & MX08: "THE ARREST" & "END CREDITS" .....	34
2.4    PRODUCTION ANALYSIS .....	36
2.4.1    SEQUENCING .....	36
2.4.2    MIXING .....	39
2.5    CONCLUSION .....	42
<b>CHAPTER III</b> .....	<b>43</b>
3    COMMERCIAL UNDERSCORE: "THE CANTERBURY GARDENS" .....	43
3.1    INTRODUCTION.....	43
3.2    COMPOSITION ANALYSIS .....	43
3.2.1    FORM.....	43
3.2.2    CHOICE OF GENRE AND INSTRUMENTATION .....	44
3.2.3    THEME AND ORCHESTRATION .....	44
3.3    PRODUCTION ANALYSIS .....	46
3.3.1    SEQUENCING .....	46
3.3.2    MIXING .....	48
3.4    CONCLUSION .....	50
<b>CHAPTER IV</b> .....	<b>51</b>
4    RADIO JINGLE "KASHI".....	51

4.1	INTRODUCTION.....	51
4.2	COMPOSITION ANALYSIS.....	51
4.2.1	CHOICE OF GENRE.....	51
4.2.2	INSTRUMENTATION.....	52
4.2.3	FORM.....	52
4.2.4	HARMONIC ELEMENT.....	53
4.2.5	COMPOSITION AND VOICE-OVER WRITING.....	53
4.3	PRODUCTION ANALYSIS.....	55
4.3.1	SEQUENCING.....	55
4.3.2	RECORDING PROCESS.....	56
4.3.3	MIXING.....	59
4.4	CONCLUSION.....	67
	<b>APPENDIX A: ORCHESTRAL COMPOSITION: FULL SCORE.....</b>	<b>68</b>
	<b>APPENDIX B: CUES FOR DRAMATIC SHORT FILM: FULL SCORE.....</b>	<b>91</b>
	<b>APPENDIX C: COMMERCIAL UNDERSCORE: FULL SCORE.....</b>	<b>98</b>
	<b>APPENDIX D: RADIO JINGLE: FULL SCORE.....</b>	<b>108</b>
	<b>ABOUT THE AUTHOR.....</b>	<b>111</b>

This original thesis was submitted to the Faculty of the University of Miami as a partial requirement for the fulfillment of the requirements for the degree of Master of Music. The project in Media Writing and Production was finished in May, 2017, and this written material is a summary of the music production process utilizing contemporary composition and audio-post production techniques. Modern studio hardware and software is discussed in the creation of music for a wide range of applications within the film, television, and radio industries. Four types of projects are discussed: writing and orchestrating an original composition for full orchestra; scoring scenes of a dramatic short film; writing an underscore for a television commercial and the production of a radio commercial, or jingle, with voice-over. Analysis of the planning, writing, programming, and production stages are followed by reflections on the challenges often faced during the different stages of the music production process.

**Keywords:** Music, Orchestration, Film Score, Audio, Post-Production



## Orchestral Composition: Carnival Of Shadows"

### 1.1 INTRODUCTION

As a composer for media, writing for orchestra is an important skill that is highly valued by filmmakers and music supervisors. The enormous palette provided by the full complement of a modern symphony orchestra gives composers a myriad of timbres to choose from when orchestrating a composition. Timbre, when used in a musical context, refers to the perceived sound quality, or color, of each instrument. The choices that an orchestrator makes can significantly alter the emotional effect that an audience has when hearing a piece of music. For example, the sound of the cello section in its high register playing a lyrical melody will have a much different sound quality and evoke a different response in the listener when orchestrated so that the same melody is played by a solo French horn.

This is just one example of the type of decisions that one must consider when orchestrating a work for full orchestra. Fortunately, we as students of music have at our disposal a marvelous catalogue of centuries of orchestral compositions written by the most creative of musical minds. With continued analysis of orchestral writing and persistent study, one can become a very effective composer and orchestrator and apply that knowledge and experience to works written for different types of media.

In today's music production environment, it is important to have experience in both orchestrating works meant to be played by live musicians as well as creating virtual performances, commonly referred to as "mock-ups." These digital recreations of what is meant to be performed by live musicians can be a challenge to massage into a good sounding virtual orchestra, and require a blend of traditional orchestration skills and virtual instrument programming skills. After composing the piece and creating the mock-up, I created the score and individual parts for each player, being painstakingly detailed in the layout and proofreading of all music until all were free of errors. The project culminated in a reading by the Frost Symphony Orchestra, giving me valuable insight into the orchestration process.

The piece I composed for the culmination of the Advanced Orchestration course is titled "Carnival of Shadows." The idea for this piece evolved from my desire to compose a work with elements of the macabre similar to much of the orchestral works from the Romantic period in music history. Some notable examples are "Symphonie Fantastique"

by the French composer Hector Berlioz (1803 – 1869) and “Danse Macabre” by another French composer, Camille Saint Saens (1835 – 1921), and “Night on Bald Mountain” by Modest Mussorgsky (1839 – 1881). The piece begins with a mysterious atmosphere created by a sustained open 5th interval in the French Horns and Bassoons. As the solo violin softly enters with the first statement of the main motif of the work, the English horn takes over the melody as it dovetails from one voice to another. This motif will reappear throughout the work in various dynamics, rhythmic variations, and in both solo and ensemble settings, and is carried boldly by the low brass section, trombones and tuba, in a final statement of this motif in the last few measures of the piece.

The fictional story I envisioned as the inspiration for the work is that of a young boy that finds what appears to be an abandoned carnival while wandering the land surrounding his family’s rural home. As he enters, the ghostly inhabitants that live in the shadows begin to emerge and the carnival comes to life, eventually culminating in an exciting finale where one can imagine a frenzy of ghosts and skeletons as the boy looks on in both fear and amazement. In this work, I sought to evoke this style and mood through my choices in the orchestration. By varying the families of instruments that I featured throughout the different sections of the piece, I sought to paint the progression of time and the rise in energy level as the listener ventures into the “Carnival of Shadows.”

## 1.2 COMPOSITION ANALYSIS

### 1.2.1 Analysis of Orchestration, Form, and Thematic Material

The primary musical motif of the piece is presented to the listener in measures three to five (motif A, Figure 1.1). I used this motif throughout the work as a type of *idée fixe*, a recurring theme that serves as the motivic foundation of a work. The motif is meant to evoke the mischief and dark whimsy of the ghostly carnival inhabitants each time it is heard. The idea is first presented by a solo violin, with a soft accompaniment of sustained D minor chord tones in two horns, two bassoons and celli, violas, and 2<sup>nd</sup> violins. I chose the solo violin in this register as it has a warm tone that can be very expressive and rich.

Figure 1.1 – Motif A - Violin Solo, Measures 3 – 6

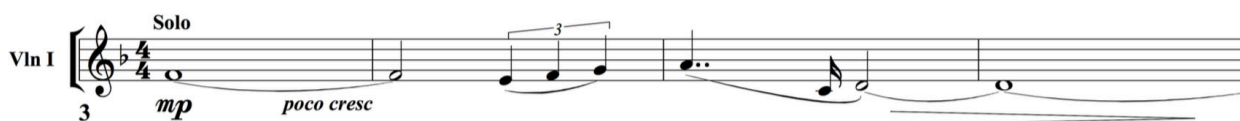

The end of the thematic statement in the violin dovetails into a repetition of this melody, reintroduced by the English horn (Figure 1.2). The sonorous tone of this instrument and the exotic feeling it evokes were the perfect match for creating a mysterious opening and for representing the initial stirring of the seemingly abandoned

carnival. The English horns' presentation of motif A in measure five is not an exact repetition of the theme as stated by the violin in measure three. It is the first variation of motif A, with the next coming two measures later in bar 7, where the 1st flute picks up the motif on the triplet quarter notes as a response to the English horn statement.

Figure 1.2 – Motif A, Variation 1 - English Horn\*, Measures 5 – 8

\*All figures and scores are transposed



At measure 13, motif B is introduced. The 1st flute (along with 1st clarinet and 1st violins an octave below, and 2nd violins two octaves below) play a pattern of four notes, “A, B, C#, and D,” where in this context it turns out to be the 5, 6th, 7th, and root of the D melodic minor ascending scale (motif B, Figure 1.3). This section of the piece is somewhat *rubato*, where the conductor leads the orchestra with an appropriate ebb and flow of the tempo as the pitches rise leading to the chord at measure 17.

Figure 1.3 – Motif B - Flute 1, Measures 12 - 17

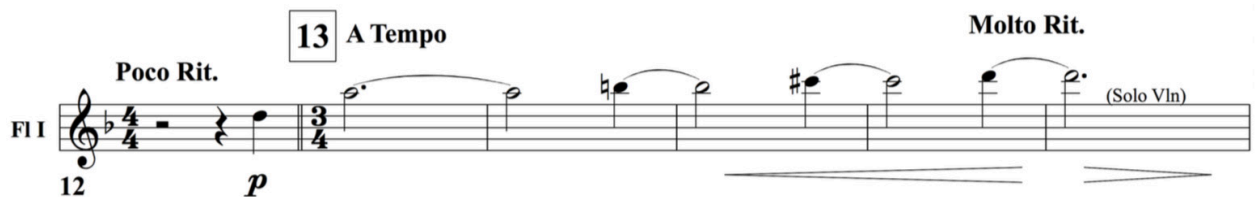

Here, almost the entire orchestra enters softly to punctuate the space left open while the flute, clarinet, and violins sustain the ascending notes of motif B. The violin solo that follows after both repetitions of motif B (measures 13 – 17 and 18 – 22) were meant to serve as ornamentation between the statements of motif B. The rising notes of motif B, the chords answering this melody, and the violin solo that follows represent the slow awakening of the denizens of the carnival. On the third repetition of motif B, we are joined by nearly the entire orchestra in a crescendo as we reach the top “D” for the third time. After this initial climax, the energy level gradually falls as the melodic material also descends to create an exhalation of the musical phrase. The orchestration thins out gradually, leaving us with only a few instruments still playing at the conclusion of this section (A, measures 1 – 31), and into the start of section B (measures 32 – 77).

Section B of the piece begins with a solo clarinet ascending staccato, or short notes, line that remains as the rhythmic foundation for the entirety of this section (Figure 1.4). The tempo here picks up from 88 beats per minute, or bpm, to 100 bpm. This is not a very large increase in tempo, or speed, but enough to create a definite pulse with this stylistic change.

Figure 1.4 – Start of Section B - Clarinet Solo, Measures 32 – 33

**32** **Moderato**  
♩ = 100

Cl I  
Solo  
mp

The strings and horns continue with an accompaniment role similar to the opening section. This serves as a link between section A and B, despite the change in tempo and style. The role of the woodwinds, though, has now changed. The flutes join the clarinets with a similar rhythm, further establishing the “waltz” feel of this section.

At measure 40, the 1<sup>st</sup> violins enter with a lyrical, yet still mysterious, new theme. This theme is in ‘*aba*’ form, a common structure in music where an idea is presented twice (*a,a*), a different idea (*b*) follows, then concluding with another repetition of *a*. The double reeds (oboe, English horn, and bassoons) take the role of providing a countermelody that contrasts the entrance of the violin melody. Although the same D minor tonality remains, the use of the natural 6<sup>th</sup> degree in the oboe and bassoon countermelody help give this section its exotic and mysterious atmosphere (Figure 1.5).

Figure 1.5 – Section B, Motif C, Vln. 1 and Countermelody (Oboe, En. Hn., and Bsn. I), Ms. 48 – 51

**48**

Ob  
mp *espressivo*

Eng Hn

Bsn I  
mp *espressivo*

Vln I  
mp *port.*

At the *b* section of this melody (measures 55 - 63), the pace picks up slightly, more felt as a slight buildup of energy than an actual increase in tempo. Here, a solo French horn introduces another variation of motif A (figure 1.6). The upwards direction of the melody on this variation and the violins joining the horn on this melody give this section a bit more of a soaring sound, before returning to the final *a* section of this melody (measures 64 – 71). Here, the rhythm of motif A is adjusted to fit within the waltz style of this section.

Figure 1.6 – Motif A, Variation – French Horn Solo, Measures 55 – 59

This final statement of this melodic material at measure 64 features a change in orchestration where the 2<sup>nd</sup> bassoon and violas are now playing a variation on the staccato solo line that the clarinet played at the start of this section, measure 32 (Figure 1.7).

Figure 1.7 – Accompaniment Example, Bassoon 2, Measures 64 – 65

At this same measure (64), the clarinets introduce new melodic material (Figure 1.8) in compliment to the violin melody. This material introduces a new triplet rhythmic pattern or motif that we will hear more prominently at measure 97 and through to the end of the piece.

Figure 1.8 – Clarinet Counter Melody, Measures 64 – 69

Arriving at measure 72, I wanted to use an element from the final two measures of this section to transition into the next part of the piece, Section C (measures 83 – 127). I chose to use the short phrase played by the flutes measure 71 as a starting point for the transition (Figure 1.9).

Figure 1.9 – Flute 1 and 2, Measures 70 – 71

I was able to create an interweaving ascending line using the bassoons then again adding the oboe and English horn, then finally in the violins and English horn with a *ritardando* and *diminuendo* leading to a *fermata* at measure 82 (Figure 1.10). By thinning out the orchestration significantly here and featuring a dialogue between smaller groups of instruments, I was able to change the character of the piece at this



point as compared to the sustained accompaniment of the violas, celli, and horns of the previous two sections of the piece. Also, by introducing the xylophone here it added a new color that evokes a kind of whimsy that is in line with the character of section B of the work. The finger cymbal that has been present throughout section B also cuts through very successfully in this more thinly orchestrated transition, also adding to the sense of whimsy.

Figure 1.10 – Woodwinds – Section A to B transition, Measures 72 – 77

As we approach the *fermata* and *caesura* at measure 77 the scale featured is the whole-tone scale (Figure 1.11). This was often used by impressionist composers in the late 19<sup>th</sup> and early 20<sup>th</sup> century to give a sense of exoticness to their music. My choice in using this scale here was also because of its tonal ambiguity, serving as a good way to end this section of the piece.

Figure 1.11 – Whole Tone Scale transition, Vln. 1 – Measures 75 – 77

Section 3 of “Carnival of Shadows” introduces a new, faster tempo, but keeps the waltz feel. The sudden loud entrance of the tuba, bass trombone, bass drum, and crash cymbal is meant to shock the listener and represents a new phase in our story. I imagined that at this point in the story much of the carnival has come to life. The cello pattern that outlines each changing chord is a variation on the accompaniment pattern introduced in the clarinet solo at measure 32, creating a link between what was heard throughout section B. Melodically, the first of our two motifs is reintroduced. Motif A, in a new variation, is now played by the violins, violas (Figure 1.12), bassoon,

and French horn as a much stronger, bolder, and decisive melody over the bouncing waltz accompaniment.

Figure 1.12 – Motif A (variation), Violin 1, 2 and Violas, Measures 80 – 83

The image shows a musical score for three instruments: Violin I (Vln I), Violin II (Vln II), and Viola (Vla). The score is in 3/4 time and G major. All three parts play a similar melodic motif, starting with a half note followed by a quarter note, then a half note, and finally a quarter note. The dynamics are marked *mf* (mezzo-forte) for all parts. The score spans four measures, with the motif being repeated and slightly varied in each.

Once again as at measure 13, we have a multi-octave spread, eventually increasing to even wider octave doublings, allowing for a growth in intensity. At measure 96, we also hear motif C in modified form played by the violins (Figure 1.13). The more agitated tempo and louder dynamics, along with the overlapping of two melodies previously heard in different contexts, helps give this section of the piece a more aggressive and frenzied feel.

Figure 1.13 – Motif C (variation), Violin 1 and 2 (not shown), Measures 87 – 91

The image shows a musical score for Violin I (Vln I) in 3/4 time and G major. The score starts at measure 87. The first measure is marked *mf* (mezzo-forte). The melody consists of a half note followed by a quarter note, then a half note, and finally a quarter note. The dynamics are marked *cresc* (crescendo) for the final two measures. The score spans four measures, with the motif being repeated and slightly varied in each.

At measure 97, the character changes to what is almost a duel between large sections of the orchestra, where the entire string section, consisting of violins, violas, celli, and double basses, along with the bassoons and bass clarinet, present an aggressive fast note pattern which is answered by trombones 1 and 3 and trumpets with a similar rhythmic pattern (Figure 1.14). This pattern is the same as the one played by the clarinets at measure 64. At the same time, the winds' upper register trills and dramatic crescendos in the horns (3<sup>rd</sup> and 4<sup>th</sup>), trombone (2<sup>nd</sup>), trumpet (3<sup>rd</sup>) create a sense of chaos. The use of dissonance through the introduction of clusters in the horn crescendo also adds to this tension.

Figure 1.14 – Trombone 3 and Tuba, Strings, Percussion – Measures. 97 - 100

This musical score shows the parts for Trombone 3, Tuba, Percussion, Timpani, Violin I, Violin II, Viola, Cello, and Double Bass for measures 97-100. The key signature is one sharp (F#) and the time signature is 4/4. The Trombone 3 part features a triplet of eighth notes in measures 97 and 99, marked with a forte (*f*) dynamic. The Tuba part plays a sustained note in measure 97, marked *mf*. The Percussion part includes a snare drum roll in measure 97, marked *f*. The Timpani part plays a triplet of eighth notes in measures 97 and 99, marked *mf*. The Violin I part plays a unison triplet of eighth notes in measure 97, marked *f*. The Violin II, Viola, Cello, and Double Bass parts all play a triplet of eighth notes in measures 97 and 99, marked *f*.

The first and second French horn parts include the same variation of motif A we heard at measure 80 in the strings, now in the French horns (Figure 1.15).

Figure 1.15 – French Horns 1 and 2 – Motif A (variation) – Measures. 97 - 100

This musical score shows the parts for French Horn 1 and French Horn 2 for measures 97-100. The key signature is one sharp (F#) and the time signature is 4/4. Both parts play a variation of motif A, starting with a half note in measure 97, marked *mf*.

At the end of this duel, the tension and excitement is raised by the use of more crescendos and trills leading to measure 105. Here, with the style descriptor given as *Furioso*, or furiously, we have a complete drop of all low frequencies and are left with a frenzied repeating pattern (Figure 1.16) played across several octaves by the piccolo, flutes, 1<sup>st</sup> violins, and violas.

Figure 1.16 – “Furioso” pattern – 2 Flutes and Piccolo - Measure 105

This musical score shows the parts for Flute I, Flute II, and Flute III/Piccolo for measure 105. The key signature is one sharp (F#) and the time signature is 4/4. The measure is marked with a box containing the number 105 and the word *Furioso*. All three parts play a frenzied repeating pattern of eighth notes, marked with a forte (*f*) dynamic.

When they enter at measure 106, the low brass gives this section a very dark and ominous sound complimented by the rising and falling fast chromatic scales in the oboe, English horn, and clarinet in measure 107 (Figure 1.17).

Figure 1.17 – Chromatic pattern in Oboe, EngHn, 2 Cl – Measures 107 – 10

The image shows a musical score for four instruments: Oboe (Ob), English Horn (Eng Hn), Clarinet I (Cl I), and Clarinet II (Cl II). The music is in 4/4 time and features a complex chromatic pattern. The Oboe and Clarinet I parts begin with a forte (*f*) dynamic. The English Horn and Clarinet II parts enter later in the sequence. The pattern consists of rapid chromatic runs with triplets and a final melodic phrase.

As the intensity of the “Furioso” section builds, measures 110 – 111 once again introduces motif A in almost its original form, but played in unison octaves by two French horns, two trumpets, and 2 bassoons. It is used to heighten the intensity, leading to a frantic build and a transition that modulates to a higher key, F minor, at measure 113.

The conclusion of the piece is a culmination of many of the patterns and motifs that occurred in previous sections of the work. The main *idée fixe*, motif A, is played by the violins (Figure 1.18), and joined on its repetition by the oboes and English horn (measure 120).

Figure 1.18 – 1<sup>st</sup> Violins - Measures 110 – 112

The image shows a musical score for the 1st Violins (Vln I) for measures 110, 111, and 112. The music is in 4/4 time and features a melodic line. The first measure (116) is marked with a forte (*f*) dynamic and the instruction *espressivo*. The melody consists of a series of notes with a triplet of eighth notes and a final melodic phrase.

The accompaniment at this point in the piece consists of fast note patterns in the celli and low woodwinds, the same pattern originally introduced by the clarinets in measure 64 and again by the strings at measure 97. The brass soars higher and higher with sustained notes that are again reminiscent of previous material derived from motif B. The final four measures feature one final statement of motif A by mainly the brass as the orchestra builds to a final chord with the celli and low winds continuing to thunder along under a final crescendo (Figure 1.19).

Figure 1.19 – Trombones, Tuba, Perc., and Strings, Final statement of Motif A - Measures 124

- 127

The musical score shows the final statement of Motif A across measures 124 to 127. The instrumentation includes Trombones I, II, and III, Tuba, Percussion (S. Cym., B.D.), Timp., Violins I and II, Viola, Cello, and Double Bass. The score is in 4/4 time with a key signature of two flats. Dynamics are marked as *f*, *sfzpp*, and *ff*. Measure numbers 124, 125, 126, and 127 are indicated at the bottom of the score.

### 1.2.2 Accompaniment

Throughout this piece, the type of accompaniment used varies depending on the mood I was trying to set and my choices in orchestration. As the piece opens, the open 5ths intervals played by two French horns in their lower range, along with the same in the violas and cello set the tone of mystery and, for only a few moments, leave the tonality (minor or major) unidentified until the entrance of the 1st violins on an “F,” the third degree of a D minor chord. This simple minor chord sustained layer is moved forward by vibraphone strikes on the first beat of each measure as the harp and pizzicato 2<sup>nd</sup> violins answer (Figure 1.20). The accompaniment created by these instruments give a solid foundation for the melodic material (motif A) in the solo violin (measure 3) and the woodwinds soon after.



Figure 1.20 – Accompaniment in Strings, Harp, and Vibraphone – Measures 1 - 6

This accompaniment is significant because it is reused in several other sections of the piece. I made the choice of using the sustained open 5<sup>th</sup> interval accompaniment figure because it allowed me to use it as a harmonic pedal over which I was able to create the harmonic progression through the relationships between these sustained notes and those moving in the instruments carrying the melody. At measure 13 this same accompaniment continues, but the sustained notes now change to accommodate the harmony under the new motif (B).

When section B of the piece begins at measure 32, this same accompaniment figure continues, but this time with more movement in the viola part. A significant change is that now some of the woodwinds add to the accompaniment by playing staccato notes that help give more rhythmic movement to this section and create the feel of a medium tempo waltz. The staccato notes in the woodwinds (Figure 1.21) help push the piece forward while both the sustained accompaniment and the lyrical melodies and countermelodies provide a contrast by playing in a more legato style.

Figure 1.21 – Staccato Section B Accompaniment, Flutes 1 and 2 – Measures 36 – 37

Measure 78 (Section C) introduces a new tempo and dynamic. The accompaniment is now devoid of any sustained notes and is purely a traditional waltz accompaniment, where instruments that play in a lower to middle frequency range, such as the double bass, tuba, and trombones, provide the strong downbeat (Figure 1.22).

Figure 1.22 – Waltz Accompaniment, Trombones, Tuba, and Perc. – Measures 78 – 79

The musical score for measures 78-79 features six parts: Tb I, Tb II, Tb III, Tuba, Percussion, and Timp. The key signature is one sharp (F#) and the time signature is 3/4. The first two trombone parts (Tb I and II) play a rhythmic pattern of quarter notes with a dynamic of *mf*. The third trombone part (Tb III) plays a similar pattern with a dynamic of *mf*. The tuba part plays a pattern of quarter notes with a dynamic of *mf*. The percussion part includes a crash cymbal (Cr. Cym.) and a bass drum (B.D.) with a dynamic of *f*. The timpani part (Timp) plays a pattern of quarter notes with a dynamic of *mf* and includes the notes (E, B, E).

Along with this, the celli are playing a modified version of the figure introduced by the clarinet as a solo at measure 32 and used as an accompaniment pattern throughout Section B. Now it becomes part of the aggressive accompaniment of this new section (Figure 1.23).

Figure 1.23 – Celli Accompaniment – Measures 78 – 79

The musical score for the cello part in measures 78-79 is in 3/4 time with a tempo of **Allegro Moderato** (♩ = 115). The dynamics are *mf* and the playing style is *unis. + arco*. The score shows a rhythmic pattern of quarter notes with a dynamic of *mf*.

The frenzied and even more aggressive section of the piece that begins at measure 97 and through the “Furioso” section at 105 uses more forceful and faster, repetitive patterns to create the tension. The dissonance caused by half-step intervals in the melody and accompaniment material also add to this. For example, in addition to the previously mentioned pattern in the flutes, piccolo, and some the 1<sup>st</sup> violins at 105, the 2<sup>nd</sup> violins and violas are playing a very fast chromatic pattern that serves as a tension-inducing murmur that creates excitement (Figure 1.24).

Figure 1.24 – Fast “Murmuring” Accompaniment, Vln. 2 and Viola – Measure 109

The musical score for Violin II (Vln II) and Viola in measure 109 is in 4/4 time. The score shows a fast chromatic pattern with triplets in both parts, creating a tension-inducing murmur.

When we arrive at the final 11 measures of the piece (measure 116), the most prominent rhythmic pattern heard is the same one initially introduced as a counter-melody at measure 64 and used in the “duel” section of measure 97 in the strings. It is combined at the end of each four measure phrase with the “Furioso” pattern previously mentioned (Figure 1.25) and carried by a large part of the orchestra, including the low strings, flutes, and piccolo. This combination of several motifs and patterns used throughout the piece is something I tried to accomplish in both the melodic elements, as previously described, as well as the accompaniment elements. By doing so, I was attempting to link different sections of the work together by using variations on recognizable patterns and motifs introduced in the first half of the piece.

Figure 1.25 – Accompaniment Pattern, Flutes 2 and Piccolo – Measures 118 – 119

The image shows a musical score for two parts: Flute II (Fl II) and Flute III/Piccolo (Fl III/Pic). The score is in 4/4 time and features a key signature of three flats (B-flat, E-flat, A-flat). The first part of the score (measures 118-119) consists of two staves. The top staff is for Fl II and the bottom staff is for Fl III/Pic. Both staves show a rhythmic pattern of eighth notes, with the first measure starting with a 7-measure rest. The pattern is characterized by groups of three eighth notes beamed together, with a '3' written below each group. The second part of the score (measures 120-123) shows a similar pattern but with a different rhythmic structure, featuring groups of three eighth notes beamed together, with a '3' written below each group.

## 1.3 PRODUCTION ANALYSIS

### 1.3.1 Sequencing

Although the ideal situation for any orchestrator or composer is to have their work performed by live musicians, the cost and/or logistics of doing so can often stand in the way. Luckily, music production software has developed to the point where we are able to use virtual instruments controlled and manipulated using a computer to realize one’s work. With knowledge of the tools and some experimentation, one can become a better “virtual orchestrator” and hopefully create convincing renditions of orchestral works.

For this piece, I used Nuendo as my Digital Audio Workstation, or DAW. This is the main piece of software where one can record and manipulate recorded digital audio files, create a score and parts to print for musicians, and use MIDI to enter the data necessary for one to create a mock-up using virtual instruments. MIDI stands for Musical Instrument Digital interface and is a protocol developed in the 1980’s to allow for the creation of hardware devices that send and receive data in a specific format that corresponds to musical information such as note pitch, note length, note volume, rhythm, and a wide array of other assignable data. Different hardware can be designed to send MIDI signals, allowing for musicians to use keyboard instruments (most common type of MIDI controller) and even controllers designed to resemble a wind instrument that can convert the intensity of air blown through a mouthpiece to MIDI data. Whether entered via a key on a MIDI keyboard, a button on an array of MIDI knobs and buttons, or even the strike of a drumstick on a specially designed

MIDI drum kit, the possibilities are endless as to what methods can be used to trigger using software designed to receive and interpret MIDI data.

In my orchestral mock-up, I entered data using mostly a MIDI keyboard into my DAW of choice, Nuendo, and used the recorded MIDI information to trigger instruments from a sample library called Hollywood Orchestra. These software instruments are each recorded individually in a professional studio, note by note, in various volumes, intensities, and musical characteristics such as length of note and intensity of vibrato. The result is a large collection of audio files that are precisely edited and incorporated into software that can be loaded into a DAW and triggered using MIDI messages. In order to more closely mimic the sound of a live musical performance, one must manipulate the data to create as realistic a performance as possible. By loading several articulation patches for each instrument, one can decide what note is played by which articulation, thus adding realism to the mock-up (Figure 1.26). An articulation is the performance technique used to play a note, for example: short, accented, slurred (no separation between notes). If one were to only use a single sustained articulation patch, notes that are meant to be played short would trigger a long sustained note that would be artificially cut off, determined by the MIDI note length. In an acoustic instrument, there are different actions performed by a player when playing a sustained note versus a short, staccato note, so more realism can be achieved when using the articulation that was recorded for that purpose.

Figure 1.26 – PLAY Virtual Instrument – Several Articulations Loaded



For certain instruments, key switches were used to switch between various articulations. Key switches are notes outside of the playable range of an instrument that



trigger the selection of different groups of samples rather than a default sound. Key switches are denoted by the blue colored keys on the far left of the keyboard in figure 1.26 (above). In the MIDI editor window (referred to as the Key Editor in Nuendo), the lane below the MIDI note data allows the user to choose the different articulations using key switches. This allows you to visualize and enter key switch data as a separate lane within the editor rather than entering actual MIDI note data (Figure 1.27).

Figure 1.27 – Key Editor – Changing Key switches on a Piccolo phrase

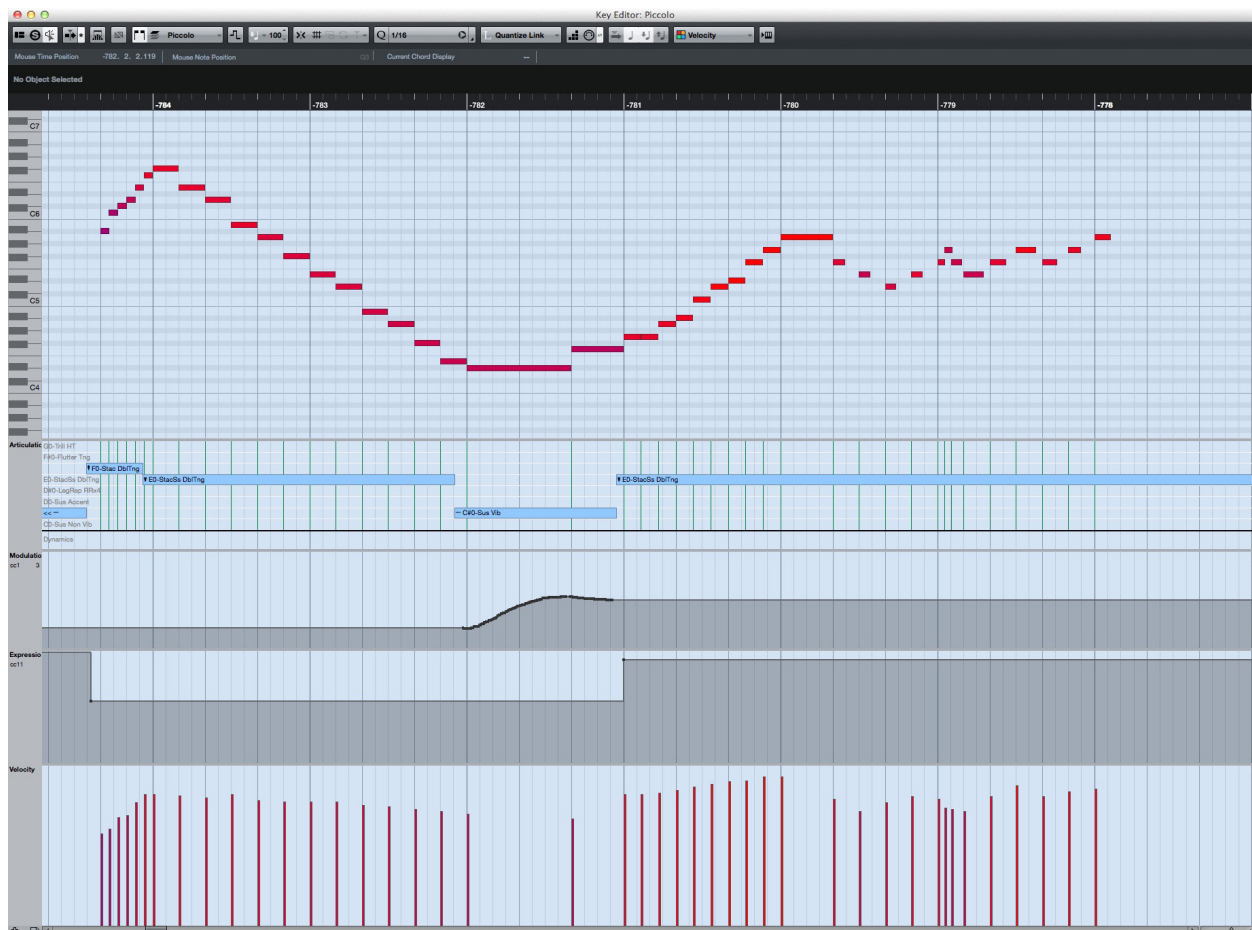

Using other MIDI data, such as Modulation and Expression, I was able to manipulate characteristics like volume and intensity of vibrato, adding further control and realism to the performance (Figure 1.28). By editing these specific MIDI parameters, vibrato and volume was increased and decreased at appropriate moments in the music with the goal of creating a realistic sounding performance of each part.



Figure 1.28 – Key Editor – Expression and Modulation in a Violin phrase

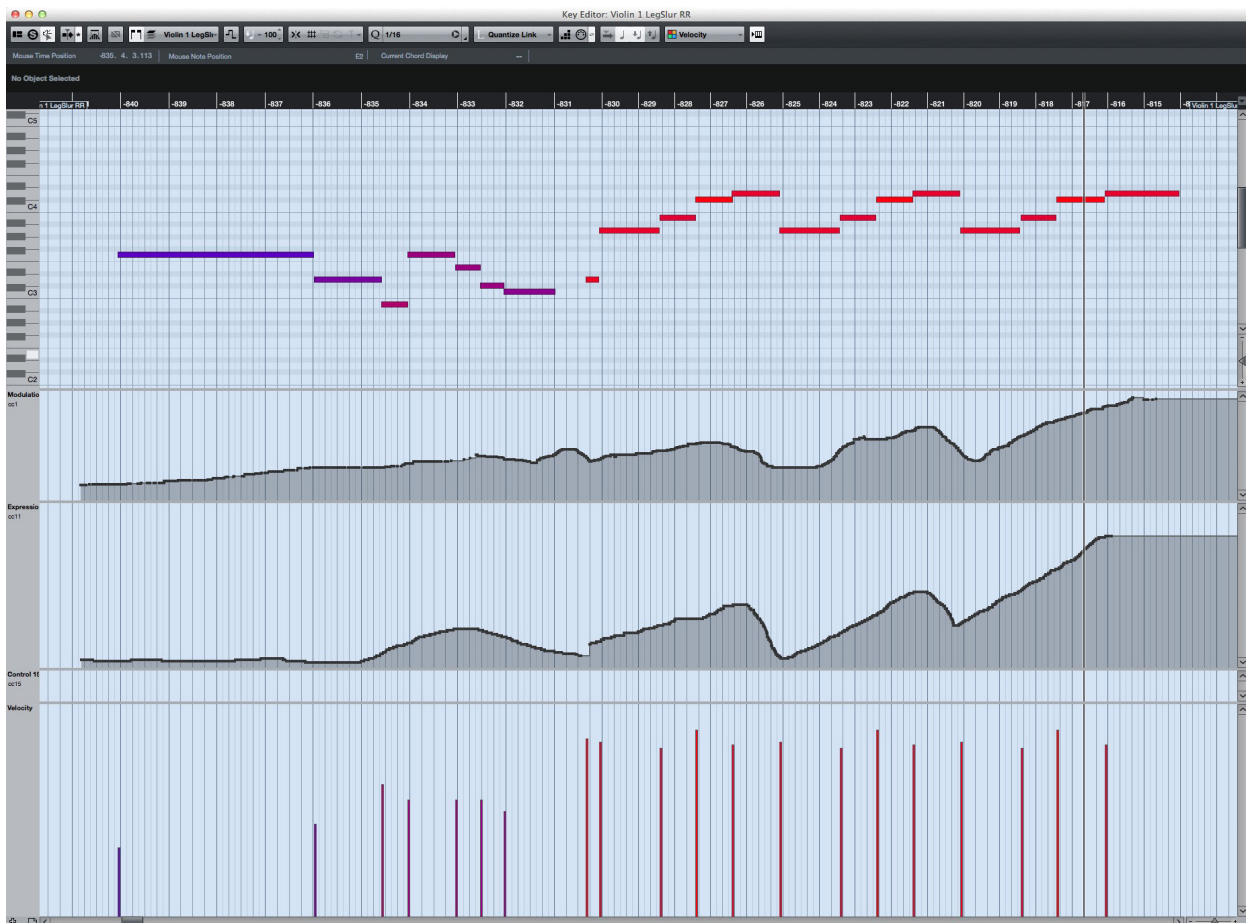

### 1.3.2 Mixing

After a piece has been composed and fully realized as a mock-up, the process of mixing can begin. Mixing is the adjustment of volume levels of individual elements of audio. This can also include manipulation of specific frequencies within an audio signal in order to boost or cut these frequencies to achieve the desired sound, also known as equalization. Rather than changing the volume of the entire audio signal, equalization allows the producer or engineer to change the volume of a single frequency or a range of frequencies in order to only affect the specific problem.

Management of dynamics, or the range of the softest sounds to the loudest, is also essential. Tools like compressors, described in detail in Chapter 4, are used to limit loudness levels to a set decibel preventing distortion and effectively reducing the dynamic range of an audio signal. When creating a mock-up of an orchestral work, this is especially useful because of the immense dynamic range that orchestral music tends to have.

Once all of the MIDI notes and controller data were entered and edited to achieve the desired sound, the next step in the process was to export each individual instrument to its own audio file. In order to facilitate this, I created buses, or groups, where the many different articulations for each instrument could be sent to in order to consolidate the many individual tracks that make up each instrument (Figure 1.29). I initially set levels for each articulation before they were sent to the buses so that when

they arrived, they were already pre-mixed. Each group was then adjusted, as needed, with changes in level, EQ, and dynamics.

Figure 1.29 – Buses/Groups, showing faders for strings and harp groups.

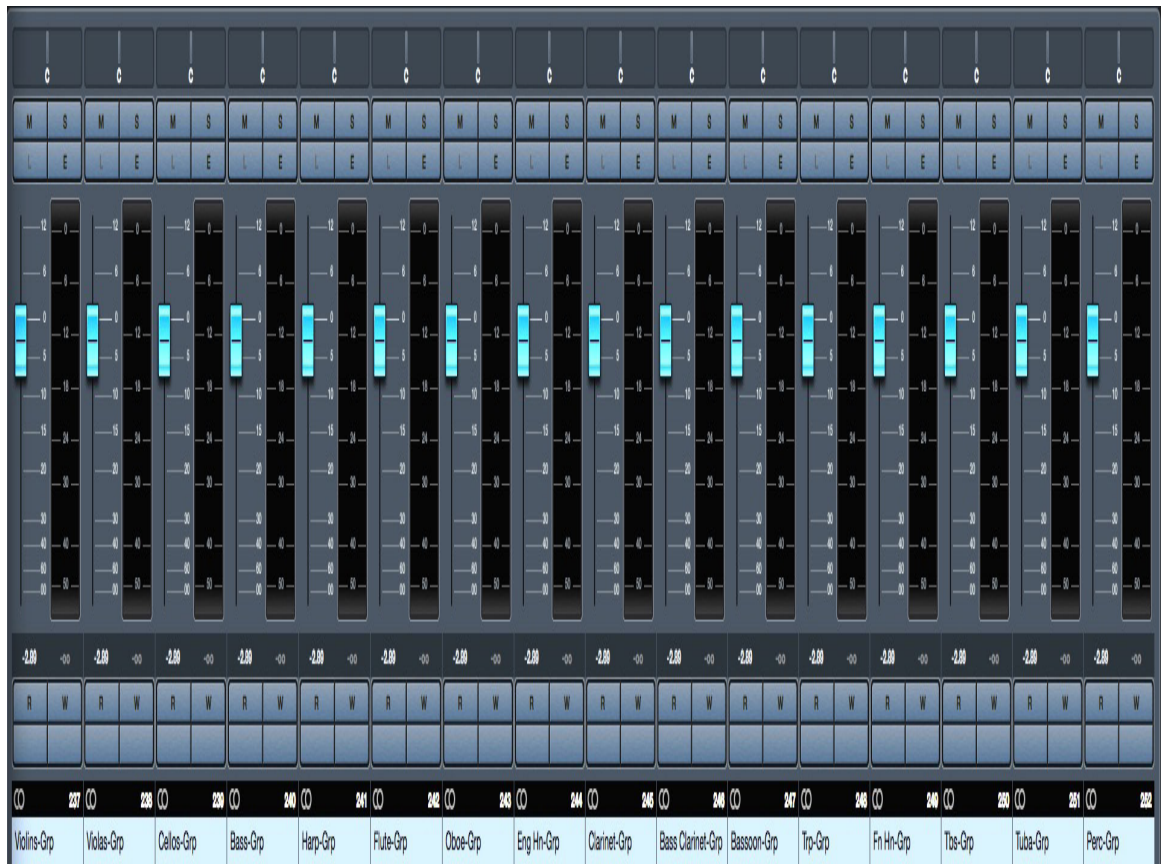

For this piece, I chose to use EQ mainly to address problem frequencies in specific instruments (Figure 1.30). For example, in the oboe group bus channel, I cut 5.5 dB at 2.3 kHz.

Figure 1.30 – Oboe Equalization



I avoided heavy use of compression and opted for controlling audio level peaks with mixing and even MIDI velocity and volume or expression manipulation at the start of the chain in order to avoid degrading “live” sound of an orchestra. When I did use compression, I used it to eliminate any peaks in the audio signal that caused levels to exceed their maximum level and causing distortion. For this reason, I chose a high ratio of 12.35:1 for steep limiting of levels once they reached a very high decibel level, but remained unaffected by the compressor prior to reaching the chosen threshold of -1 dB (Figure 1.31).

Figure 1.31 – French Horn Bus Compressor

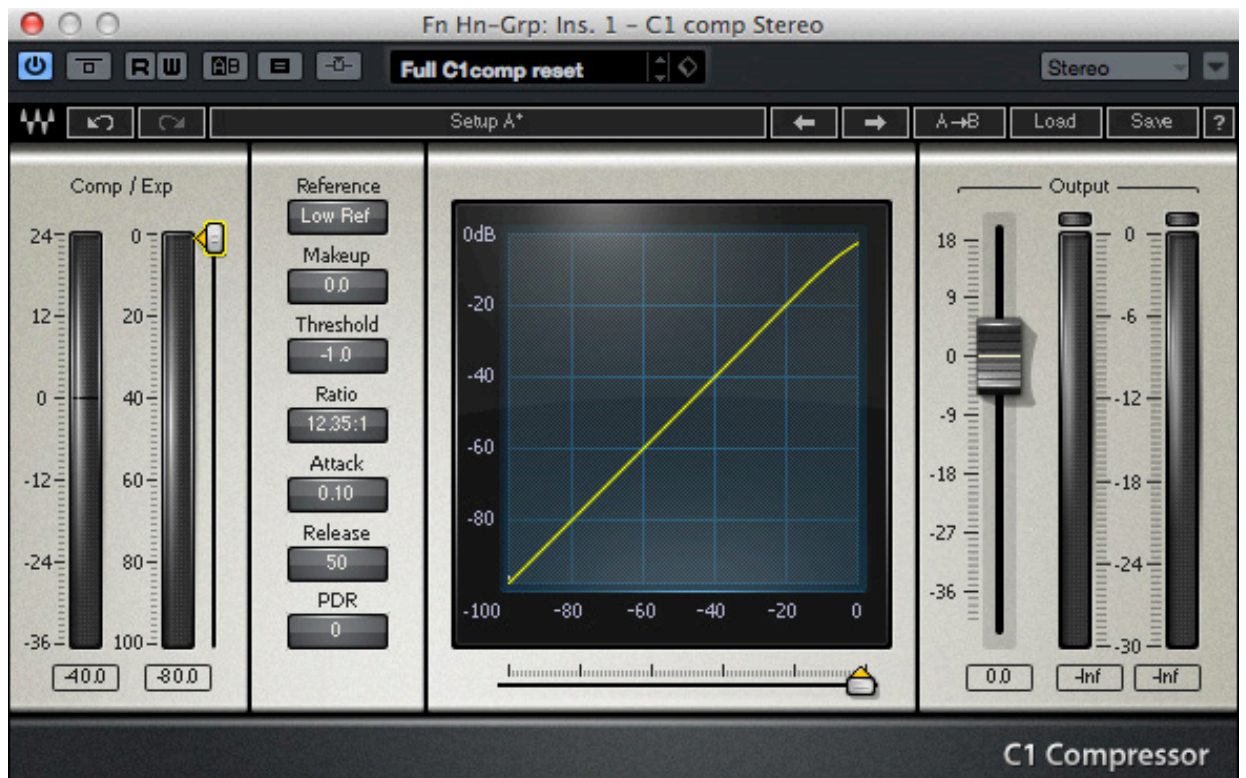

I proceeded by routing all of my instrument groups, including those shown in figure 1.29, to one group I called “Main Grp.” The purpose of this group was to be able to then easily send this output to a reverb effect using an auxiliary send. An auxiliary send is a way to direct an audio signal to another channel in order to apply different processing than the original audio, and then mix the signals back together using a return bus, also referred to as an effects bus or group. In this case, the signal was processed using AltiVerb, a reverb effect plugin that has digital models of the acoustic characteristics of concert halls, studios, and unique spaces from around the world (Figure 1.32). I chose a concert hall called the “Konserthuset,” located in Stockholm, Sweden.

Figure 1.32 – Reverb Plugin, Effects Send

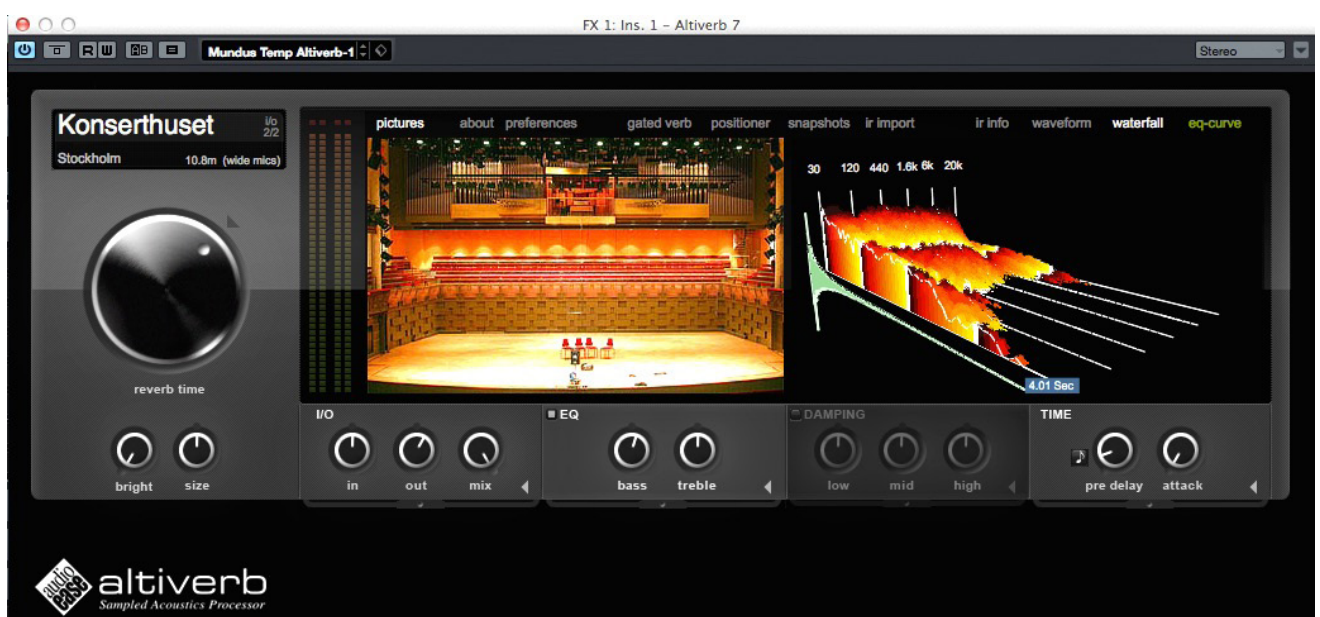



Both the original audio signal and the reverberated version are then fed to the master output of the DAW, where it is then possible to export the final audio to a single stereo (2-channel) audio file that is compatible for playback on any system that supports digital audio. Here, I applied a dynamics processing effect known as a limiter, used for limiting audio signals above a certain threshold (Figure 1.33). This is the same concept as a compressor but it is meant to serve as even more control over peaks as the ratio is set extremely high, usually above 10:1. This served as one final preventative measure prevent any distortion. My general rule when mixing this piece was to control errant peaks in audio levels as early in the signal chain as possible so that less drastic processing was needed as the audio was consolidated into buses further along the chain. This allowed for the need to apply very mild amounts of dynamics processing at the end of the signal chain once dozens of individual articulations, instruments, groups, and send effects were summed together.

Figure 1.33 – Dynamics Processing, Main Output



## 1.4 CONCLUSION

Writing and orchestrating my original piece was an immense challenge that gave me the opportunity to grow musically. As I orchestrated the piece, I also created a mock-up of the work that I hoped would help give me an idea of what the piece would sound like when performed by live musicians, while trying to always remain aware of how different traditional orchestration can be from virtual orchestration.

Attending the reading of the piece by the Frost Symphony Orchestra was one of the most instructive parts of the project, as it was very informative to hear how each musician, conductor, and the orchestra as a whole interpreted the music. I was happy with the reading and gleaned valuable insight into the effectiveness of not only my writing and orchestration, but also my score and part notation and layout. Being a clarinetist in an orchestra myself, I am very aware of how much of a difference the appearance of your part can have when sight-reading a new piece. Avoiding anything that may cause hesitation or confusion on the part of the player and conductor is paramount, especially considering the limited amount of time available for the reading of each student's work. I liken this to the pressures of a recording session where a large sum of money is invested in hiring the people and space necessary for a recording of an orchestra, and of course, time is limited. I hope to encounter many opportunities in the future to further improve my orchestral writing.

## Opening Cues and Final Cues for Dramatic Short Film: “Rankling”

### 2.1 INTRODUCTION

My second semester in the Media Writing and Production program provided me with the opportunity to gain first-hand experience in collaborating with filmmakers to score a short film. The compositional approach to writing music for a film is very different than when writing concert music. The composer must decide what is needed musically in a scene to enhance the scene, never overshadowing or taking attention away from the story. Every scene will call for a different approach and opinions amongst composers and filmmakers can vary greatly in how to most effectively accompany the onscreen action. Through collaboration with the director and by studying the work of film composers over the past hundred years, one can begin to develop the important skill of scoring a dramatic scene.

For this project, I was fortunate to experience the process from early on in the development of the script through to the final post-production and the screening of the film. The film is titled “Rankling” and written by Lourdes Roche and directed by Lourdes Roche and Lorenzo Ponce de Leon. I will discuss the musical cues, the term often used to refer to the musical score composed to a scene in a film, composed for the opening title and first scene, and the final scene of the film and end credits.

After reading the script several times, I annotated points where I thought music might work for the film. I spoke to the filmmakers about the film and that gave me a great starting point in understanding the mood of the film. I was also aided by their “character study”, a 1.5-minute compilation of film footage they created to give a feel for the desired look of the film and characters using clips from several different Hollywood films. It also included a music track chosen by the writer and director that was very helpful in guiding my initial ideas for a theme. As another helpful reference offered by the filmmakers, I watched parts of the film, “Winter’s Bone.”. After watching this film and reviewing the script in detail, I thought of other works that might help guide me in a musical style or genre. The HBO series “True Detective” and a film titled “Mud” came to mind. They both shared the gritty Americana feel that I felt would be appropriate for the short film. Meeting the filmmakers and hearing their vision for mood of the film and of specific scenes and characters helped guide me further and giving me all of the information needed to begin composing a theme.



The two-minute cue that I composed in the two weeks after reading the script was received with great enthusiasm from the writer/director and producer. They were very happy with the sound palette and the melody I composed and we all agreed that the rest of the cues for the film should be developed from this idea. Knowing that the amount of time allotted for post-production would be very limited, receiving this approval gave me great comfort. I was confident that I would be able to develop the rest of the score from these two minutes of music.

## **2.2 PLOT OVERVIEW AND SCENE DESCRIPTIONS**

The 10-minute film, titled “Rankling,” is a story about a woman who hires a friend to kill a lover. From their conversation in the opening scene, we infer that the three of them committed some kind of robbery together in the past. We observe the conversation between the woman and the friend as she asks him to murder their mutual accomplice. The friend agrees to do it in exchange for a large sum of money. The final scene of the film shows the downfall of our vengeful main character as she is arrested attempting to flee her trailer-home while carrying a duffel bag filled with bundles of cash and bags of white powder, assumed to be drugs. Convinced that the hit had been taken care of by the friend (he confirmed the lovers’ death with a photograph earlier in the film), she is shocked as she is met outside by the police and none other than the friend she hired for the hit - and the lover himself, alive and well - both of them apparently working as undercover detectives throughout the film.

## **2.3 COMPOSITION ANALYSIS**

### **2.3.1 Cues MX01 & MX02: “Opening Title” & “The Proposition”**

The film opens with the title of the film fading in over a close up of a dark, burning object. At this point, the viewer does not have any context for what this object might be, but a similar shot towards the end of the film reveals that this close up is a burning polaroid photograph showing the corpse of the main character’s lover, the target of the assassination. After about twenty seconds, the film fades to the opening scene (MX02), the conversation that leads to an offer of money in exchange for the murder of their mutual friend.

For cue MX01, I chose to use a simplified version of the melody that I composed as part of the theme completed prior to the film being shot and edited. My idea was to use this melody at key points throughout the film, the first being the presentation of the film’s title and again when the photographic evidence of the hit is being burned by the main character, and finally at the moment when the woman is arrested and the film cuts to black as the title again appears (Figure 2.1).

Figure 2.1 – Main Theme, as presented by Banjo I in MX01: “Opening Title”, Measures 3 - 6



When I composed the initial two-minute cue that I sent to the filmmakers prior to filming, I tried to create a dark, foreboding mood, with a hint of a poignancy, featuring instruments that are often associated with the “Americana” sound: banjo, guitar, fiddle, double bass. I chose to also use synthesized instruments and effects processing of the acoustic instruments (in the form of virtual instruments and effects plugins) to provide me with more tone color options when creating the dark atmosphere needed for the film. I used some of these synthesized instruments to create a low frequency pad (sustained tones serving as a foundation for other material) over which the acoustic instruments could serve more melodic roles. In the opening title, this pad creates a rumbling and ominous bed over which the banjo and solo violin present the main theme: the banjo with the first half and the violin taking over with the conclusion of the phrase (Figure 2.2). The violin double stops, the string technique of bowing two or more notes at one time, along with the banjo sound, were used in the opening cue in order to establish the “Americana” sound. Together with the dark texture created by the synth pad, my intention was to create a feeling of suspense and of ominous things to come in the story.

Figure 2.2 – Cue MX01: “Opening Title”, Measures 1 - 8

Americana, Dark, Foreboding

\*Notes Trigger Unpitched Synth Effect - Tassman VST

In the transition from the opening title to the first scene, I chose to keep the same synth pad, but rather than continuing to sustain, the pad strikes a single tone that resonates for a few seconds between each new entrance of the next note. The pattern is not completely regular, with the time between each note entrance varying in order

to accommodate the dialogue. When composing this cue, I recorded the synth part without a steady tempo and later found a tempo that worked with my performance.

After trying out several ideas where I used denser harmonies and additional melodic material, I eventually decided that this cue was more effective when kept simple. I used the synth pad to play only a single note on each entrance, with the banjo joining the synth on more or less every other note. The decision of when to change the pitches, and thus the implied harmony, was something else that I struggled with and went through many variations when composing this cue. I tried to let the dialogue guide me, and changed the pitch depending on the level of tension created by what the character was saying at that moment (Figure 2.3).

Figure 2.3 – Synth Pad I, Measures 17 – 20

17                      18                      19                      20

### 2.3.2 Cues MX07 & MX08: “The Arrest” & “End Credits”

The dramatic final scene of the film opens with a shot of our main character retrieving a black duffel bag hidden in a closet. From earlier in the film, we know that she has a large amount of money stashed away, but she has been lying about where she has hidden the money in the years since the crime our three characters committed together. After receiving the photograph proving that assassination had been completed as well as an unnerving visit by police asking if she knew of the now missing man’s whereabouts, she has decided to collect her money (and drugs, as the audience is soon shown) to make a run for it.

I decided to begin the cue at the moment where the main character places the duffel bag on a table. The first sound heard is the same synth pad that was the sole instrument heard for most of MX02. My intention was to create tension by using the synth pad in a similar pattern of regularly repeating single tones with a limited sustain to the sound so that there would be some space between each note struck. The pitches played by the banjo are those that make up the main theme of the film (Figure 2.4). I also used an unpitched sound design texture (Synth Pad II) to accentuate the moment at the start of the cue when the audience is shown the bricks of white powder in the bag, indicating to the viewer that she is still involved in drugs, contrary to statements she made earlier in the film.

Figure 2.4 – Main Theme, as presented by Banjo I in MX07: “The Arrest”, Measures 4 - 9

4                      5                      6                      7                      8                      9

At the moment in the scene when the main character realizes she has been caught, the filmmakers chose to completely fade out the sound effects and ambience,

with only the score audible for the final minute of the film. I chose to feature sound design elements and create a very resonant sound that builds and sustains when we see the main character's expression of shock and fear, as she raises her arms to surrender to the police outside her home. My idea was to create a texture that would give the viewer the impression of what the character would be feeling at that moment: confusion, shock, fear, sadness. I thought that this was another point in the film where it was better to use less instruments or elements in the music to create a tenser and more foreboding atmosphere.

The next few shots we see of her being led away in handcuffs and put into a police car are followed by the reveal that her friend from the opening scene, whom she had hired to kill her ex-lover, is a detective working undercover along with ex-lover himself to catch and arrest the main character with the hidden money in her possession. The shots leading up to the reveal are edited using hard cuts, an editing technique where there is no transition used between different shots. This prompted me to accentuate some of this cuts with entrances of instruments such as the double bass and synthesizers. At the reveal, the pulse of the music begins to become evident because of the introduction of a moving guitar line and the entrance of the solo violin playing double stops similar to those in the opening title. I built the intensity and momentum in the music by adding additional layers, like the banjo doubling the guitar line, as we see the main character handcuffed and sobbing in the back of a police car, realizing that her greed and bitterness has led to her downfall.

The film cuts to black, with the end title, "Rankling," appearing as white text. I chose to accent the appearance of the end title by starting the first full presentation of the main theme at this moment. Up until this point in the film, parts of the main theme have been heard played by several instruments and in different tempos and variations, such as the opening title and the beginning of this cue. I made a conscious effort to withhold the main theme presented in its entirety and orchestrated in a fuller and more emotive way until the end of the film so that it would hopefully have more impact. The melody is played as a duet between two solo violins again using double stops and a combination of heavy vibrato on certain notes and a non-vibrato playing style on others in order to evoke the feeling of the "Americana" style, where a violinist would not always use the traditional Classical European style of violin playing (Figure 2.5). The two solo violins were chosen to heighten the emotion, as this instrument can play in an extremely lyrical and emotive manner.

Figure 2.5 – Main Theme, as presented by Two solo violins in MX07: "The Arrest", Measures 22 - 26

The musical score for two solo violins (S. Vln I and S. Vln II) in 4/4 time, measures 22-26. The score is marked with a forte (*f*) dynamic and "molto espressivo" performance instruction. The notation shows a duet with various rhythmic patterns and double stops. The measures are numbered 22, 23, 24, 25, and 26 at the bottom of the score.

While developing a plan for the scrolling end credits, sometimes referred to as the “end crawl,” I decided to use more of the music I had composed for the filmmakers as my initial thematic idea. In the demo cue, I had begun with a sparser introduction that led into the main theme and violin duet. By reworking this music to fit after rather than before the main theme, I was able to change the mood and pace of the score at a key moment in the credits when the full cast and crew list begins to roll. This created a necessary change of pace that I felt worked because the main theme comes to a conclusion while seamlessly continuing into cue MX08 with the more subdued end crawl music. At this point, I chose to not use the violins and limit the orchestration to the synth pads that create the foundation of the music with the banjo taking over the lead role.

## **2.4 PRODUCTION ANALYSIS**

### **2.4.1 Sequencing**

The music for this cue was composed and produced using Nuendo as my DAW and several software instruments created by East West, Native Instruments, and Applied Acoustic Systems. The acoustic instruments, such as the steel guitar, banjo, and violins came from East West libraries while the synth elements and acoustic bass came from Native Instruments libraries. All of the music was entered as MIDI data using a MIDI keyboard and manipulated with the same techniques described in chapter 1 of this thesis: expression and modulation MIDI controller data and key switches (Figure 2.6). I also used effects such as reverb and delay to create the necessary ambience sound design elements I wanted to use throughout the film.

Figure 2.6 – Main Theme, Solo Violin I: “The Arrest”, Measures 23 - 27

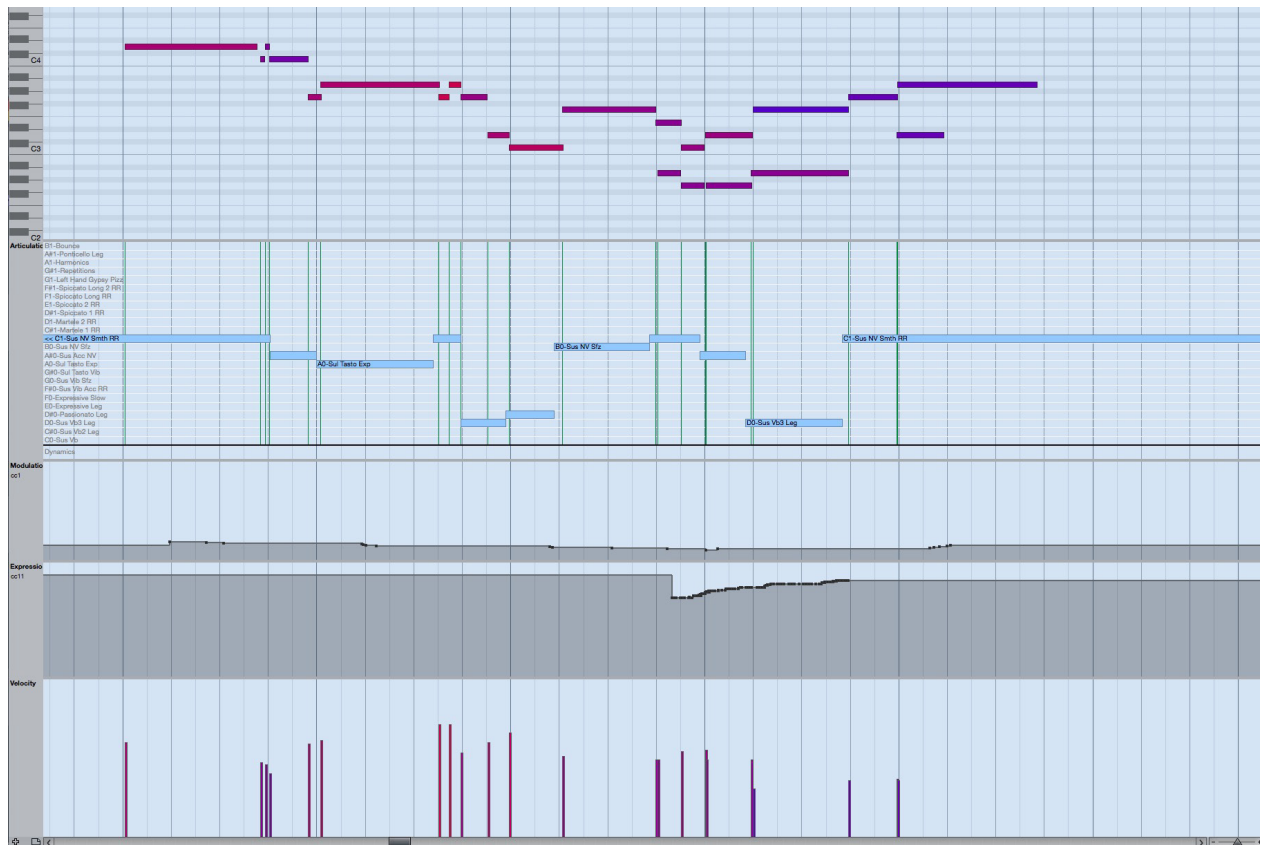

For the non-acoustic instruments, I searched through a large number of presets in various synthesizers instruments such as Massive, Absynth, Reaktor, and Tassman, until I found and made note of several that were possibilities for the types of pads that I was looking for. After finding a preset within Absynth that I liked, I dove deeper into the preset, using it as a starting point from where I began changing settings related to the types of oscillators (a module with selectable waveforms that create varying timbres) and the ADSR envelopes (Figure 2.7). ADSR is an acronym for attack, decay, sustain, release. These modules allow control over the volume of a note in the time domain. Working from these patches allowed me to retain some of what initially drew me to the preset while customizing specific parts of the sound in order to better match what I was envisioning for the timbre I wanted to create.

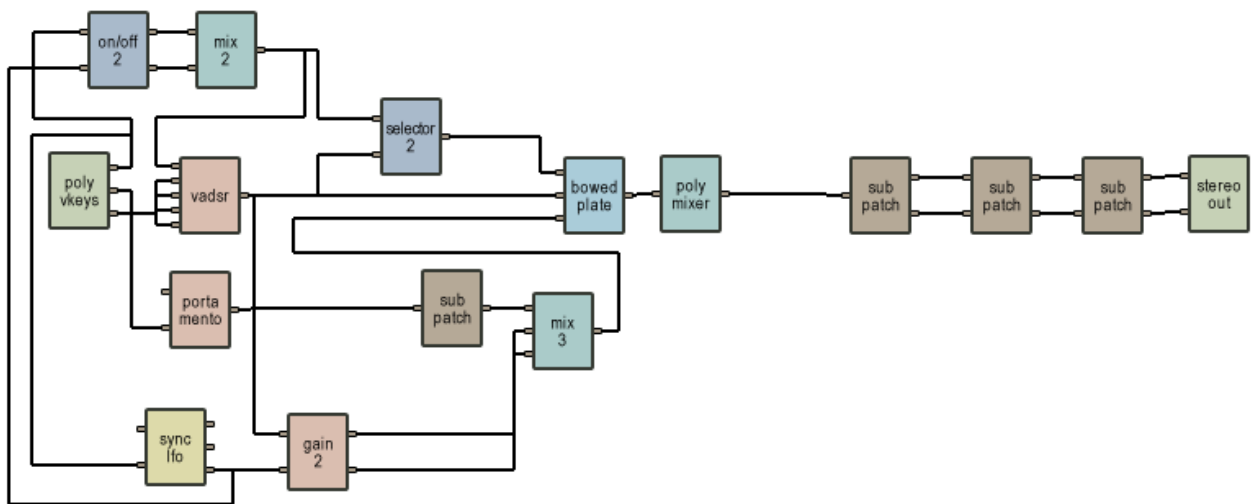

Figure 2.7 – Synth Pad I – Absynth ADSR Envelopes



The second synthesizer I used is called Tassman, a physical modeling synthesizer created by Applied Acoustics Systems. This synthesizer uses mathematical models of real world objects such as strings and tubes in order to create unique sounds. Characteristics of these objects, such as size and the point at where in the object it is being struck, can also be modified. It is a modular synthesizer, meaning that the user has access to the inner workings of the instrument so that modules such as oscillators and filters can be connected in different configurations depending on the desired results (Figure 2.8). The instrument shown as “Synth Pad II” in the score refers to the material played by the instrument Tassman. The physical object used in this patch for sound creation is a metal plate, and the exciter, the object used to trigger the metal plate, is a bow. Exciters in synthesis are objects that cause a vibration and can be (as in this case) a bow, the strike of a stick, or even a blow of air.

Figure 2.8 – Synth Pad II – Tassman Modular Editor View



### 2.4.2 Mixing

To place instruments in different ambient spaces, I used several different reverb patches from Altiverb: Todd-AO Studios, Cello Studios (live room 1 and 2), and the Notre Dame cathedral in Chartres, France. Using automation, I varied how much signal from each virtual instrument was sent to the reverbs throughout each musical cue in the film. Automation is a feature of a DAW that allows you to record the movements of almost every control within the virtual mixer and plugins. In addition to using reverb in its more traditional manner, I also used it to create a very “wet” version of the banjo. The term “wet” in audio is used to describe a signal that has audio processing applied to it, versus the “dry” signal, which would have no processing applied to it. The means of controlling the exact mix of “wet” and “dry” signals will be described shortly. I used the very “wet” banjo as one of my elements to provide ornamentation in key moments to give a mysterious and ambient feel to the music, while still retaining the “Americana” acoustic sound of the banjo.

I used the same technique but with different effects processing on a strummed guitar in order to allow me to accent certain moments with a chord of my choosing, but heavily effected with reverb and delay (“Guitar FX” in the score). Both of these instruments were sent to these effects using an auxiliary send to an effects or group bus. As previously described, this allows you to direct the audio signal from the original source and send it to a separate bus channel that can then be manipulated as desired, without affecting the original signal (Figure 2.9).

Figure 2.9 – Banjo and Violin VST Inst. Channel Auxiliary Sends

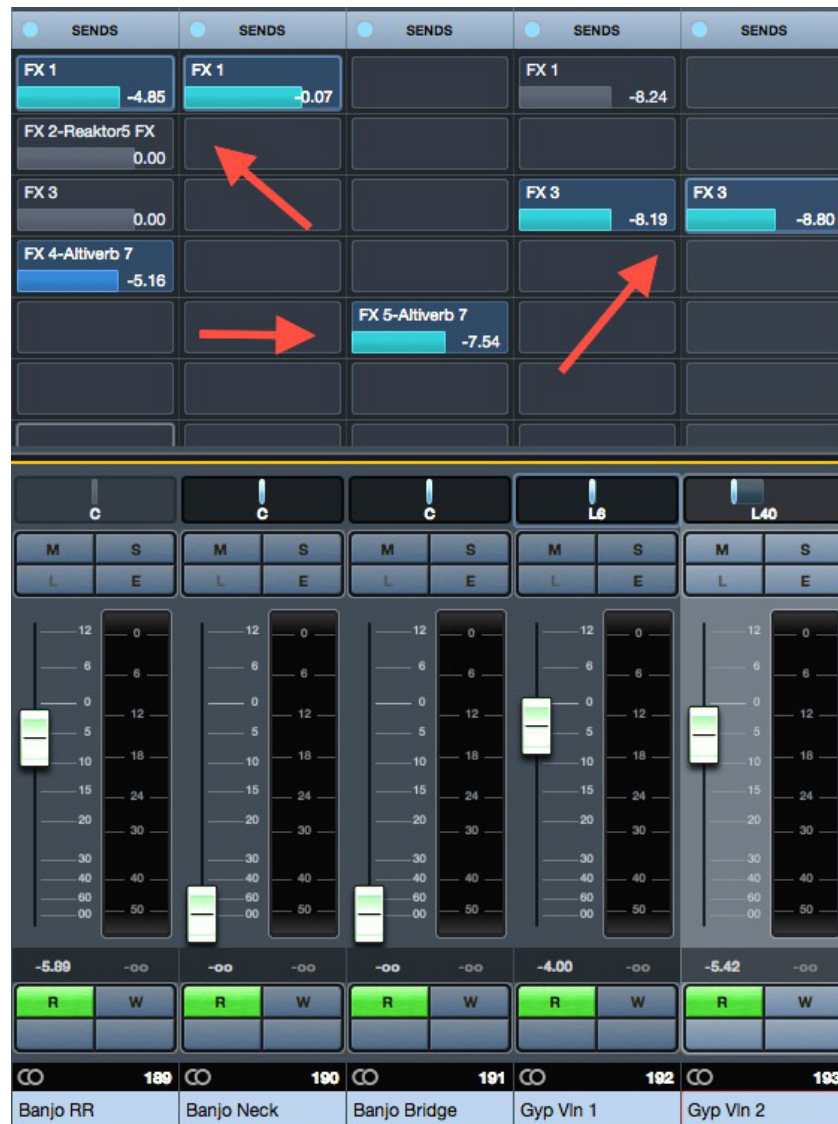

I placed my reverb and delay effects on these bus channels and used varying amounts of send level from the source channel to send to the effected buses. I chose to set most of the sends to pre-fader mode as opposed to post-fader mode. Pre-fader mode means that the audio signal is routed to a return bus before the audio on the channel is affected by the level fader. This allows you to have independent control of the dry, unaffected signal level and the effected audio signal at the return bus. In post-fader mode, turning down the channel fader of the source signal would also affect how much of that signal is being sent to the send bus because the signal is taken after the channel fader.

My approach for mixing these cues did not involve exporting individual instruments as audio files, or stems. For this project, I mixed all of the material within the same project that I was using for the scoring process, without employing the traditional method of exporting individual audio files for mixing. One of the reasons I chose to do this was because the number of instruments and other elements was relatively small. The processing power required for this project did not heavily tax my computer and so I did not need to export elements to audio in order to regain processing power. Another reason I chose this method was because of the tight deadline and constant

adjustments to the footage, requiring adjustments to the tempo map and composition. By not exporting audio stems, I was able to save time as the deadline approached because I retained the freedom to change every aspect of the score, down to even individual notes, without needing to re-export the audio stems each time a new version of the film was given to me.

Knowing that I would most likely not be exporting audio stems until the end of the project, I tried to be attentive to the mix as I composed and edited the cues and the material was still able to be manipulated as MIDI data. I then exported the finished music as a single stereo audio file. When mixing my finished music in relation to the film audio, I used the audio provided with each new version of the footage. Unfortunately, this audio was still raw for the most part, as no equalization, dynamics processing, or noise reduction had been applied to it yet. For the cues discussed in this chapter, only cue MX02 contained dialogue. Because of this, the issue of not having the final processed film audio to work with did not hinder me greatly when mixing. In fact, most of the musical cues in the film were not under sections of the film where there was dialogue or other film sound.

Once I delivered my final stereo audio files to the filmmakers, the final mix was done by the editor, director, and producer. In an ideal situation, I would have delivered stems of my cues to a mix engineer who would have had access to stems of all other film audio (dialogue tracks, natural sound, foley) and the final mix would have been done by that person in collaboration with the team. Because this was a very low budget student film, much of the work normally done by those specialized in each particular step of the process was done by myself and the filmmakers.

## 2.5 CONCLUSION

Working on the score for this film provided me with an opportunity to apply my composition and orchestration skills to writing a score to a dramatic film. I initially had a great deal of trepidation when reading the script and speaking to the filmmakers about the genre and style of the film. I was unsure of my ability to adapt to the musical style necessary to make the score effective. But my hesitation soon dissipated once I began investigating references and thinking of the approach I would take when composing the theme. The theme written weeks prior to the shoot based off of the script was well received by the filmmakers and this enabled me to be extremely efficient when finally scoring the film. The sound palette that I created for the theme provided all of the inspiration and sound sources used for all of the cues in the film. The theme itself was used in mostly its original form in the final cue, while one of the synthesizer patches I modified to create an important texture in the score provided part of the material used in the opening cues. I believe that the work I put into familiarizing myself with the script, the character study, and the music that the filmmakers chose as reference for the sound and style of the score (often referred to as “temp” music), gave me the confidence to tackle the scoring of the film quickly and effectively.

## Commercial Underscore: “The Canterbury Gardens”

### 3.1 INTRODUCTION

Composers today are called on to write music to accompany visuals for a variety of mediums. When writing music to accompany a television commercial, considerations must be taken to properly enhance the story that the footage is meant to convey to the viewer. When appropriate music is used in conjunction with visuals, the message that a filmmaker is trying to impart can be greatly enhanced. The emotional impact that both the commercial and the music have on their own is dramatically increased when an appropriate combination of both is achieved.

The third chapter of this paper focuses on music written for a one-minute commercial. The project involved writing a synopsis and description for a fictional advertisement to which I would then write a score to enhance the story told by the proposed visuals. This created the challenge of developing a concept for the commercial that one could then effectively compose a score.

### 3.2 COMPOSITION ANALYSIS

#### 3.2.1 Form

The title of the television program for which I wrote an underscore is “The Canterbury Gardens.” It is a period show set in England during the early 1900’s, similar in style and look to the popular BBC show, “Downton Abbey.” In the story, William Canterbury, patriarch of the Canterbury family, has just passed away and is survived by his wife, step-mother to his four children from another marriage. Sofia, his oldest child and only daughter, must navigate the turbulent fallout of her father’s death, as the inheritance of the family fortune has turned everyone against each other. It is in the Canterbury gardens, the sprawling and luscious grounds surrounding the Canterbury Estate, that Sophia discovers a thread of lies that leads her to investigate her father’s death and question all those that surround her.

I envisioned that the commercial would begin with long overhead shots over the English countryside, in the distance one can see a train traveling through the lush landscape. We cut to an overhead shot of the train, then the train approaching a station. We then cut to a horse-drawn carriage approaching a large estate, followed



by shots of the grand Canterbury Estate and surrounding gardens, leading to interior shots of opulent rooms inside the mansion. The music throughout this first part of the commercial should be more subdued and slowly build, not just in dynamics but through changes in orchestration. At this point the commercial would be about halfway through, or at around 30 to 35 seconds, when we see some of the main characters in quicker cuts showing action and interest-piquing shots of violence, sex, crying, screaming, confrontation, fighting, and guns being fired. The music here would reach what I will call the B section, with a change in the harmonic progression and rhythm, orchestration, and melodic material with the objective of creating a more intense and passionate atmosphere. The climax in the music would be timed with the appearance of the main title of the show, “The Canterbury Gardens.”

### 3.2.2 Choice of Genre and Instrumentation

For this piece, I felt it was appropriate to use only orchestral instruments in my virtual ensemble. I decided to use piano, strings, two oboes, two English horns, and two French horns.

I featured the piano during the introduction, let the woodwinds and strings take over the melody shortly after, and used the horns to provide more power towards the end of the commercial. I listened to a few cues from the previously mentioned television series, “Downton Abbey” for inspiration and to get a feel for what musical elements, techniques and orchestration choices gave the music the appropriate sound and style to invoke era, location, and type of drama presented by the visuals.

### 3.2.3 Theme and Orchestration

When composing my initial piano sketch, I tried to come up with a rolling left-hand pattern in the piano that could be used for rhythmic momentum throughout the work (Figure 3.1). After some experimentation with this motif and developing some melodic ideas as well, I came up with a basic set of motifs and form for the piece.

Figure 3.1 – Piano, Measures 1 - 4



Because I was not writing to visuals, only a description of the visuals, I estimated that at about 30 seconds into the piece, I would need to advance to the B section of the cue where the intensity and passion of the music would need to increase to match the faster cuts and more dramatic images at this point in the commercial. I also decided early on that the melody in the second half would be played by the violas or celli (Figure 3.2).

Figure 3.2 – B Section Melody, Viola and Cello Section Divisi, Measures 32 - 39

In order for the piece to effectively grow in intensity at an appropriate pace, I tried to make each new phrase gain power through changes in the orchestration rather than simply increasing the overall dynamics or volume. The piano motif moves the piece forward with a constant eighth note pattern in a triplet feel, as shown previously in figure 3.1. A solo English horn and the 1<sup>st</sup> violins playing an octave higher introduce the slow moving melody in measure nine (Figure 3.3), and the 2<sup>nd</sup> English horn, violas, and celli continue with a repetition of the phrase.

Figure 3.3 – English Horn I Melody, Measures 9 - 15

At measure 22, the oboes, flute, and bassoon join the group for the transition into the more energetic and lyrical section of the underscore (Figure 3.4). These instruments all have timbres that I felt would be very effective in evoking the atmosphere necessary for the visuals. Some of the musical reference I used in the composition of this piece include composers Ralph Vaughn Williams (1872 – 1958) and Percy Grainger (1882 – 1961), who drew influence from British folk music in their work. Much of their writing is often associated with the “sound” of the English countryside.

Figure 3.4 – Woodwinds, Measures 22 - 27

In Section B, the melody is played by the celli and viola. The addition of a French horn in a unison doubling of the celli creates more intensity as we move towards the climax of the music. For the conclusion of the piece, I composed a phrase with a large interval leap leading to a *tutti* accent followed by a *crescendo* growing from *piano* to *forte* dynamics. This swell played by the entire orchestra was used to help the music reach its final climax.

## 3.3 PRODUCTION ANALYSIS

### 3.3.1 Sequencing

When hired to compose the score for a commercial, a mock-up is a great way to present drafts to a client during the scoring process. In projects where the budget is too low to account for the cost of live recordings, one may need to use a mock-up as the final product. For this reason, it is important to strive for as much realism as possible in the virtual orchestration process. For this project, I used Nuendo as my DAW and East West virtual instruments as my sound library.

For the majority of the woodwind instruments, I used patches that include a number of articulations that can be selected using notes outside of the playable range of the instrument, known as key switches (Figure 3.5).

Figure 3.5 – English Horn Virtual Instrument Plugin, Main Panel



By using the MIDI Expression feature in Nuendo, I am able to view and select each articulation in a lane within the traditional piano-roll MIDI editor (Figure 3.6). This type of editor shows the notes of a keyboard across the y axis and time is displayed across the x axis. The key switches are represented by the blue keys in the lower octave of the VST instrument keyboard, as seen above in figure 3.5.

Figure 3.6 – French Horn I Melody, MIDI Data, Measures 40 – End

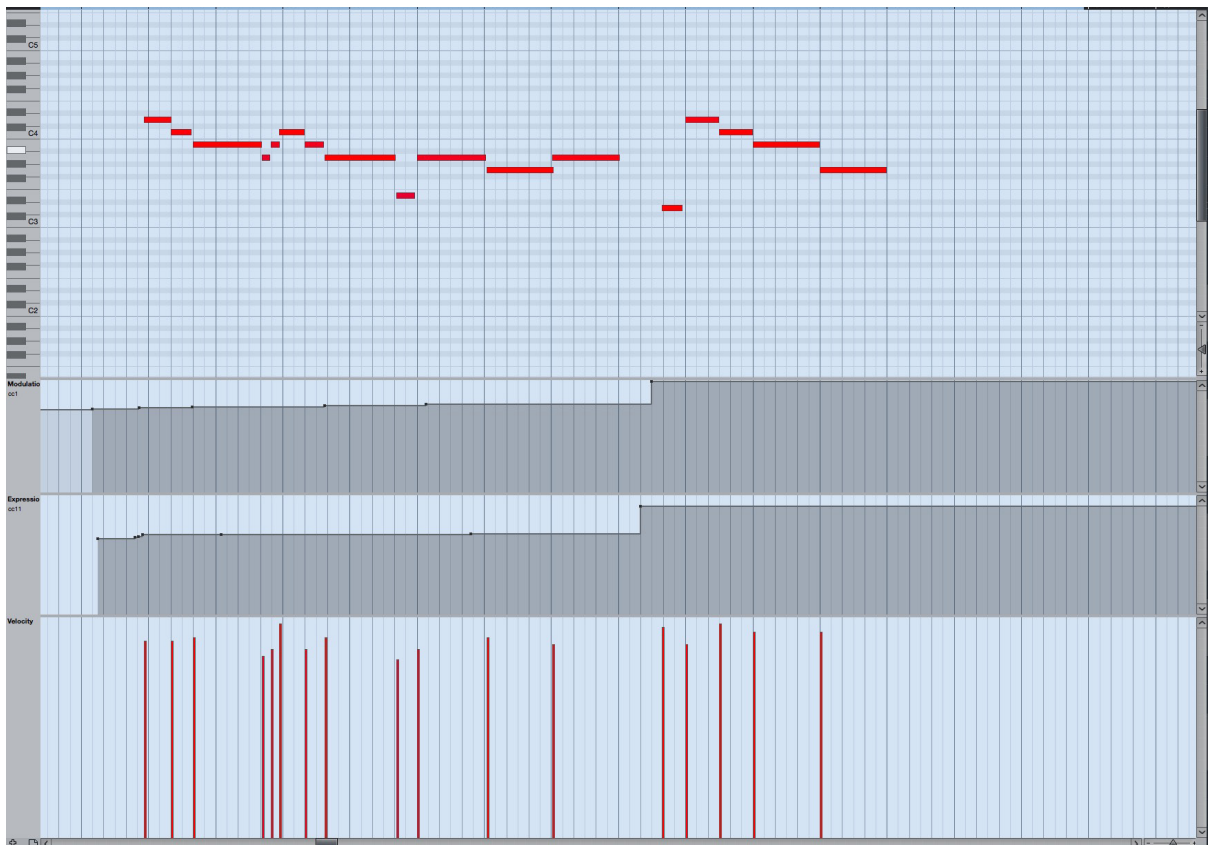

For other instruments, like the French horn, I chose to use individual articulation patches. Because certain articulations are not included as part of the key switch patches, using individual patches (as described in chapter 1) spread across several MIDI channels is often a useful method. For the B section at measure 32, I used the French horn legato slur patch because it does a great job at reproducing the nuances in the sound produced when transitioning from one note to another on this instrument.

The East West software instrument piano patch I chose for this piece is a Bechstein. After trying out several different type of pianos, I decided on the Bechstein because I preferred its warm sound to that of others in the library. I also chose to use the “player” mic position rather than the “room” position because I preferred the more intimate sound of the closer recording position (Figure 3.7). Because the piano is the featured instrument in the first eight measures of the piece, I felt that hearing it in a closer mic position before the rest of the ensemble is introduced was an effective way to begin the piece. For the rest of the orchestra I used the “main” mic, which is the equivalent position to that of the “room” mic in the piano software instrument.



Figure 3.7 – Piano Virtual Instrument



### 3.3.2 Mixing

To facilitate the process of mixing, I created buses where the audio signal of the different articulations for each instrument in the same way as described in Chapter 1 of this paper. Equalization and control of dynamics using compression was addressed early in the signal chain on the channel strip of the individual articulations. These consolidations, or groups, were then summed in a bus labeled “Main GRP”. This enabled me to use a send bus to direct the signal to an individual channel with a reverb plugin as an insert effect. Finally, the dry (unprocessed) and wet (processed) versions of the signals were sent to the stereo output (Figure 3.8).

Figure 3.8 – Group, Effects, and Main Output Channels

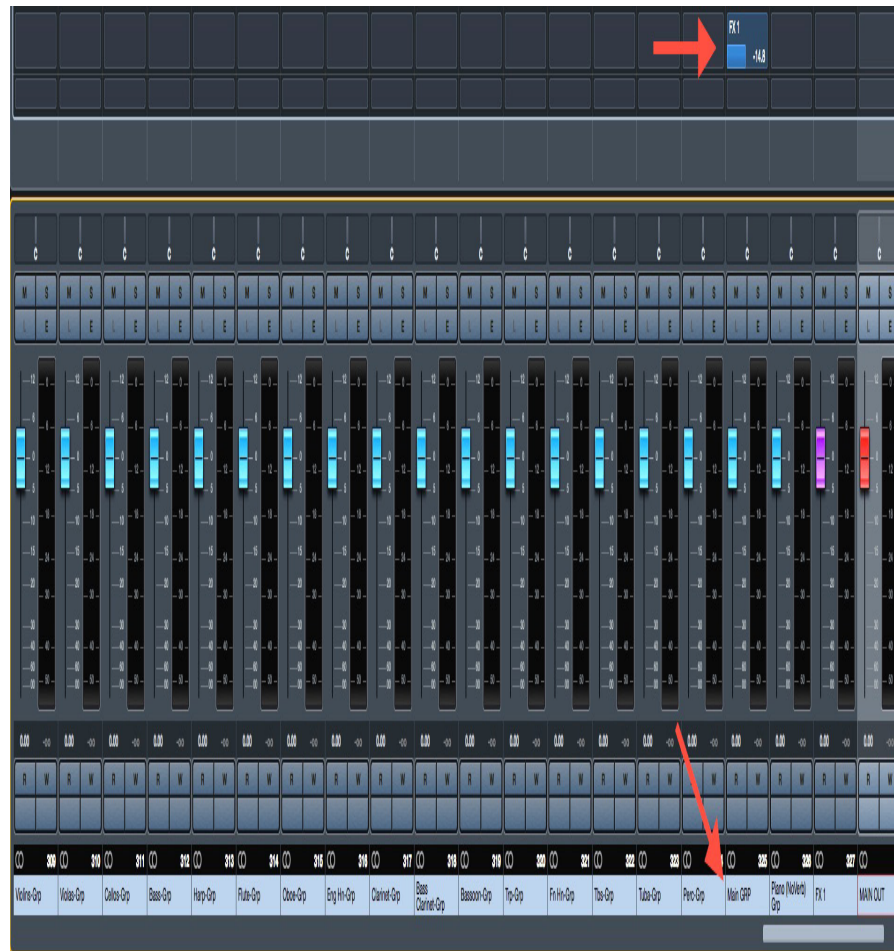

The reverb effect I used for this piece is called Altiverb, a reverb effect plugin that has digital models of the acoustic characteristics of concert halls, studios, and unique spaces from around the world (Figure 3.9). I chose a concert hall called the “Konsertthusut,” located in Stockholm, Sweden. The long reverb time and size of the hall gave the appropriate sense of space for the orchestra that I felt would add more realism to the sound of the mock-up.

Figure 3.9 – Altiverb Reverb Plugin

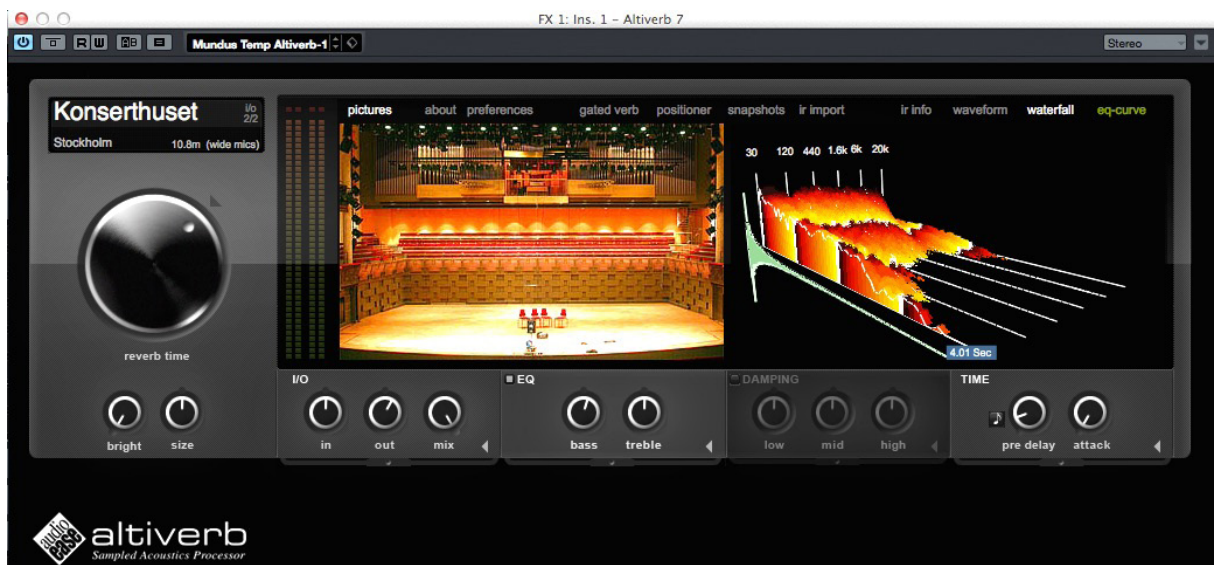



### 3.4 CONCLUSION

After receiving feedback from my fellow students and professor, I was able to revise my score and refine it to better match the story I had written describing the visuals of the commercial.

They felt something to help conclude the piece was needed and my solution was to use the French horns to play a final bold statement of melodic material. It was a challenge coming up with the style of music and instrumentation that I felt would allow me to best illustrate the commercial, but after investigating some references I was able to determine what my best course of action would be. I learned that the process of composing a commercial underscore can be facilitated by working step by step to achieve the goal. Even before I began composing, I had already researched other scores in the genre, decided on instrumentation, and even decided on a basic structure or form. Although some of these decisions changed during the composition and production process, having a foundation upon which to build allowed me to be more efficient.

### 4.1 INTRODUCTION

Creating a radio advertisement involves the merger of various skills within music and audio production and post-production. The skills required involve not just composing the music for the commercial, but also writing the lyrics to the vocal part, the voice-over, and recording and editing these and all other instruments to an exact time requirement. The producer must consider the specific needs of the client, which can vary greatly depending on style of the commercial and the type of company and product being advertised. Appropriate consideration must always be given to matching the genre of music to the product as well as choosing the voice-over artist to help convey the desired message.

For this project, I chose to produce a radio commercial for Kashi, a company that sells cereal and granola products with a focus on sustainable food production and a healthy lifestyle. I decided to use acoustic instruments including guitar, drums, piano, solo violin and cello because I felt that a laid back, “earthy” feel was appropriate for this type of advertisement. After studying their website and getting a feel for the way that Kashi tries to present itself to customers, I began the composition process.

### 4.2 COMPOSITION ANALYSIS

#### 4.2.1 Choice of Genre

Another important decision after choosing the company I would be writing the jingle for was the musical genre. I wasn’t sure of what to call the style I wanted to write in but I had an idea of the sound I was going for. After researching commercials produced for companies that sell similar products or try to embody the same kind of principles in the products they sell, I found a few examples that helped narrow down my ideas.

Another source of research and inspiration that was extremely helpful was searching through the catalogs of established production music libraries. These collections usually include a large selection of music in a variety of styles and are often composed and edited to fit 30 second or one-minute time slots. This was an invaluable resource

as I was able to analyze different tracks to determine the characteristics that made the music successful at evoking a specific mood.

#### 4.2.2 Instrumentation

I chose to use a standard rhythm section of drums, bass, piano, and acoustic guitars as the foundation for my ensemble. In addition, I used a solo cello during certain moments in the music. A female vocalist was recorded singing the brand slogan: “Enjoy Real Food” as well as reading the voice-over script. I used two acoustic guitars, one featured as the opening instrument to set the mood under the voice-over, and the other as a rhythm guitar. To give the commercial an extra touch of warmth and a “natural” sound, I decided to use a solo violin as well, featured at the beginning of the commercial.

#### 4.2.3 Form

Although only thirty seconds in length, there are three distinct sections in the commercial. The introduction sets the atmosphere, with only the acoustic guitar playing an arpeggio pattern under the voice-over (Figure 4.1). An arpeggio is a group of notes that outline a chord.

Figure 4.1 – Acoustic Guitar, Measures 1 - 3



After the first spoken line introducing the company and what they are about (“... making our foods with simple, wholesome ingredients that are good for you”), a short break in the voice-over (measure 5) allows for the drums and bass to enter with a simple beat that continues

through to the end of the commercial. The descending figure played by the bass on beat 4 of measure 7 alters the harmony to a dominant sus4 chord for that brief moment, helping create the “Americana” sound (Figure 4.2). Also starting at measure 5, the violin plays the melody that is later also sung by the vocalist, along with a solo cello counter melody.

Figure 4.2 – Full Score, Measures 5 - 8

The musical score for measures 5-8 is arranged in six staves. The top staff is for Vln/Vox, with measure numbers 5, (V.O. 2), and (V.O. 3) indicated. The second staff is for Cello (Cel). The third staff is for Acoustic Guitar (Ac. Gtr), with chord symbols E, G, D, and E written above the notes. The fourth staff is for Piano (Pn). The fifth staff is for Bass (Bs). The sixth staff is for Drums (Dr), with a '\*Fill' symbol above the first measure. The key signature is three sharps (F#, C#, G#) and the time signature is 4/4.

In the second section of the ad, the message of what Kashi wants for its customers is delivered: “At Kashi, we want you to enjoy real food, that’s made simple, made better, with organic ingredients for progressive nutrition.” After this line is spoken, the vocalist and solo violin join with the slogan: “Enjoy real food,” while the cello provides the countermelody (Figure 4.3). The piano also enters here in order to fill up the overall sound more as we approach the end of the jingle.

Figure 4.3 – Solo Violin, Voice, and Solo Cello. Measures 9 - 12

The musical score for measures 9-12 shows two staves. The top staff is for Vln/Vox, with measure numbers 9 and (V.O. 4) indicated. The bottom staff is for Cello (Cel). The lyrics "En joy Real Food" are written above the Vln/Vox staff. The key signature is three sharps and the time signature is 4/4.

#### 4.2.4 Harmonic Element

The harmony of the composition is a simple pattern of three chords, always returning to an E major root chord (Figure 4.4). The pattern helps create a relaxed atmosphere and does not take away attention from the voice-over by being too out of the ordinary or unexpected to the listener. This would be undesirable as it would distract the listener from the most important part of the jingle, the product being advertised.

Figure 4.4 – Harmonic Progression, Measures 6 - 8

The harmonic progression diagram shows three measures in 4/4 time. The first measure contains a G major chord, the second a D major chord, and the third an E major chord. Each chord is represented by a sequence of notes on a staff.

#### 4.2.5 Composition and Voice-Over Writing

The only real instruments in the music are acoustic guitar and voice. Drums, bass, piano, solo violin, and solo cello were all virtual instruments. When composing the

jingle, I used virtual instruments to simulate the guitar and voice that would eventually be recorded by live musicians.

To begin the composition process, I loaded a virtual instrument piano created by East West, Piano Platinum, and used the Bosendorfer patch. I used the piano to experiment with chords and melodic ideas. As I developed my ideas, I also settled on a tempo that felt natural for the style of music and also worked well in terms of musical phrasing and the 30 second time restriction for the radio commercial. After some considerable work and editing, I had a structure and a melody that would also serve as the slogan for the brand with the lyric: “Enjoy real food (Figure 4.3).”

I eventually settled on the idea of starting the commercial with the acoustic guitar plucking the individual strings of the E major chord in a repeating eight-note pattern. After the first few notes, the voice-over enters, and soon after, the solo violin. I tried to time the voice-over so that the violin entrance landed near the moment when the script read the word “philosophy.” I felt that the soothing character of the violin in a duet with the acoustic guitar would help evoke the nature and health conscious attitude that the brand wants to convey.

After the voice-over comes to a natural pause, I chose to have the drums, electric bass, and a strummed acoustic begin playing so that the energy of the commercial would be raised considerably. The second statement of the script reads: “At Kashi, we want you to enjoy real food, that’s made simple, made better, with organic ingredients for progressive nutrition.” This is the strongest statement of the commercial so far, so I felt it was appropriate to have the drums and bass join at this point.

At the end of this second voice-over statement, the phrase “enjoy real food” is sung and the solo violin doubles the melody. The final statement, with a friendly and inviting tone, reads “Kashi, made simple, made better,” followed by a short conclusion in the music.

When writing the voice-over, I felt it was important to include the name of the brand, Kashi, in the script as many times as possible. Because the medium is radio, this type of advertisement cannot rely on visual cues to implant the brand in the audience’s mind. By repeating the name of the company several times, hopefully there is a greater chance of it being remembered. Also both the sung melody and lyrics, “enjoy real food,” and the end voice-over tag, “Kashi, made simple, made better” are phrases that are both repeated twice in the 30 second script (Figure 4.5). This was also an intentional attempt at brand recognition.

## **Kashi Jingle – V.O. Script**

Javier Albornoz

### **V.O. 1:**

Here at Kashi, we hold true to our philosophy...making our foods with simple, wholesome ingredients that are good for you.

### **V.O. 2:**

At Kashi, we want you to enjoy real food, that's made simple, made better, with organic ingredients for progressive nutrition.

### **V.O. 3:**

Kashi, made simple, made better.

## **4.3 PRODUCTION ANALYSIS**

### **4.3.1 Sequencing**

The virtual instrument library I used as my drum kit for this project is Studio Drummer, by Native Instruments. After listening to many of its different kits, I settled for a great sounding patch called Session Kit. This library allows control over the level of each microphone used to record the drum kit, as well as the level of the room microphones. Room mics are often used to record drums in order to capture the sound of the space where the kit was recorded. Using only the signal from the individual mics tends to sound dry and clinical, as each microphone is normally placed very close to the sound source. Room mics are positioned six to ten feet away (depending on the size of the room) from the kit in order to capture the drum sound with the ambience caused by the reflections of the sound within the recording space. By combining the individual mics with the room mics and finding an appropriate balance between these sources, it is possible to create a realistic drum track using a software instrument.

The virtual bass I used was a Native Instruments library called Scarbee Pre-Amped Fat, loaded within the Kontakt VST plugin, the software sampler that Native Instruments uses for most of the instruments in its collection. I felt this particular instrument had a very appealing warmth to its sound, but lacked some definition to its upper frequencies. After auditioning several other bass sounds, I decided to use the Scarbee Pre-Amped Fat preset and address the inadequacies in the tone by using compression and equalization during the mixing phase.



Although I knew that I would be recording a live guitarist for this project, I used another patch from the Native Instruments Komplete 10 collection to create a mock-up of my guitar parts during the composition process. This was helpful because it allowed me to experiment and make decisions that would help me prepare for the live recording. In order to recreate a strummed guitar sound, I used the Akkord Guitar library. A feature of this software instrument is the ability to choose different strum patterns that automatically adjust to the tempo set in the sequencer. To simulate the plucked guitar notes at the beginning of the jingle, I used the “plucked” version of this instrument.

To create my solo violin and solo cello parts, I once again used instruments from the East West Hollywood Orchestra library. By using the same techniques described in the first three chapters of this text, I tried to program the violin and cello parts to sound as realistic as possible. For both instruments I used the key switch patches in order to switch between various articulations and used the expression and modulation MIDI controllers to adjust volume and vibrato parameters.

As previously mentioned, I chose to use the Bosendorfer patch within the East West Pianos Platinum library as my virtual piano. By using the “Player” mic position, I was able to achieve a more intimate sound like the kind that one would get from a close position mic in a small studio environment.

#### 4.3.2 Recording Process

The recording of the acoustic guitar tracks took place in the Media Writing and Production studio at the Frost School of Music. In a standing position, the guitarist used an Acoustic Dreadnaught V501N, made by the brand Vintage. The microphone, an AKG brand C414 condenser mic, was set up and positioned about eight to ten inches from the body of the guitar, pointing towards the area at about the 14<sup>th</sup> fret. A condenser microphone uses an electrically charged thin conductive diaphragm that reacts to incoming sound pressure changes that cause a change in the diaphragm's capacitance, then causing a change in the output voltage. The position chosen for the microphone is a common acoustic guitar close mic technique that allows one to color the sound significantly depending on where the microphone is pointing. With the cardioid polar pattern selected, a microphone picks up sound in the area directly in front of the diaphragm and depending on whether the mic is pointing more towards the sound hole or towards the neck of the guitar, a widely different tone can be captured. Towards the sound hole, more pick sound and body will be captured; towards the neck one captures a lot of the string sound from the left hand and a brighter tone. I settled on positioning the mic towards the area around the 14<sup>th</sup> fret, as the guitarist and I agreed that this position was giving us a nice round sound with the right amount of brightness.

The microphone signal was fed through a Universal Audio 4-710d. This is used to boost a low level signal, in this case from the microphone, to a level that is strong enough for processing and recording. This particular preamplifier has a tube preamp

based on classic guitar amplifier design, as well as a preamp using proprietary technology called “transimpedance” that provides transparent amplification. After setting the gain to a strong enough level (bottom left knob, Figure 4.6), I experimented with the middle knob. This feature allows you to choose how much of each type of preamp is being used to amplify the mic signal: all the way to the left and only the transimpedance preamp is used; all the way to the right only the tube preamp is used. I found that by setting the knob at about the 2 o’clock position I was able to create an acoustic guitar tone that had a great deal of warmth to it.

Figure 4.6 – Vocal Microphone Pre-Amplifier – Universal Audio 4-710d

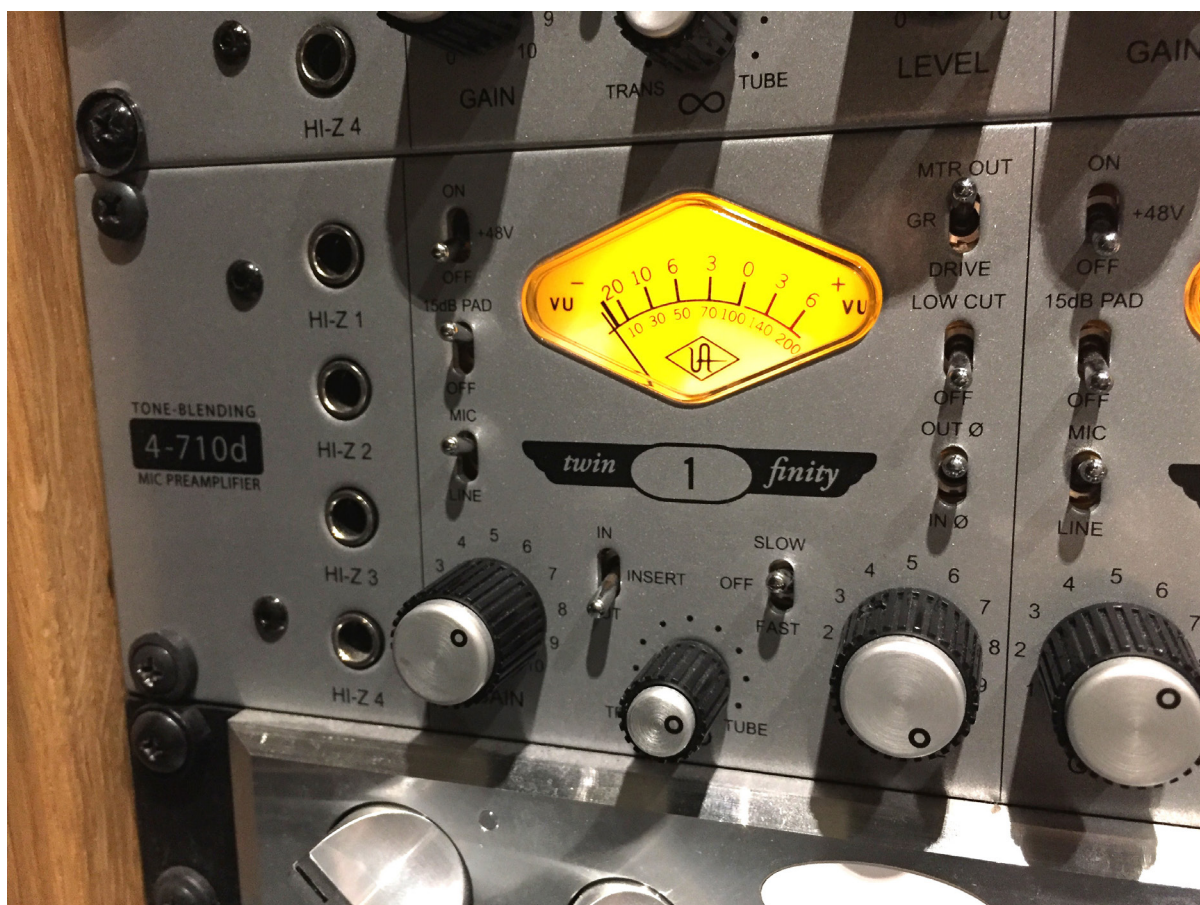

To aid the players during each recording, I created individual audio files of each instrument from my mock-up and used a metronome click to give the performer references in order to play at the correct tempo and with the right musical phrasing and emphasis. We recorded several takes of the plucked guitar arpeggios, with several retakes starting at each chord change in order to create a smoother transition between the broken chords. A composite track was then edited together using these takes.

After recording the plucked chords, we recorded several takes of the strummed guitar chords. Because this part was notated only as chord symbols, I discussed several options for strum patterns with the guitarist. He was able to demonstrate various patterns that he felt would be appropriate for the style, and after some discussion we agreed on one we both felt would sound great with the rest of the ensemble.

During two additional recording sessions with two different female vocalists, the same microphone, an AKG C414, was used to record the lead vocal part as well



as the voice-over (Figure 4.7). I used a device commonly referred to as a gobo and positioned it to block unwanted reflections from the wall that divides the studio live room and control room. A gobo is an acoustic isolation panel that is usually made up of a wood frame covered with some type of sound dampening material (foam, carpeting, etc.). It can be placed in the position that works best at minimizing reflections during a recording. The wall separating the live room and control room has various large glass windows that can create undesirable reflections that negatively alter the sound captured by the microphone.

In order to reduce the popping sounds that can result from fast moving air on the diaphragm of the microphone, I placed a pop filter in front of the microphone. The stretched nylon helps reduce the sound created when certain consonants are vocalized, for example, the “p” in the word “power.”

Figure 4.7 – Vocal Microphone Setup w/ Gobo and Pop Filter – AKG C414



The signal from the microphone was fed through the same preamplifier used for the guitar recording, the UA 4-710d. Again experimenting with the balance between which preamp type was more prevalent, the transimpedance or tube preamps, I opted for setting the knob at the 11 o'clock position to record the lead vocal.

When recording the voice-over, the preamp settings were adjusted slightly in order to record the best possible signal with a healthy amount of gain and no distortion. When creating the mock-up and writing the voice-over, I used the marker track within my DAW to write the text and check that the timing of the lines would work (Figure 4.8). I read the lines during playback in order to estimate the pace needed for the lines to fit within the allotted time for each sentence. Once I had settled on the final script,

I copied the verbiage from my marker track into a text document for the recording. This document was placed on a music stand at an angle rather than directly behind the microphone. Fabric was also placed on the metal music stand to dampen any reflections caused by it.

After the initial takes, I tried to give constructive feedback to the voice-over artist regarding the tone that I was envisioning to help convey the message of the script. We recorded several passes of the entire script, then focused on each individual section of script and tried to capture different readings with the emphasis placed on different words. This gave me the benefit of having various options during the editing process.

Figure 4.8 – Marker List – Nuendo – Voice-Over Script

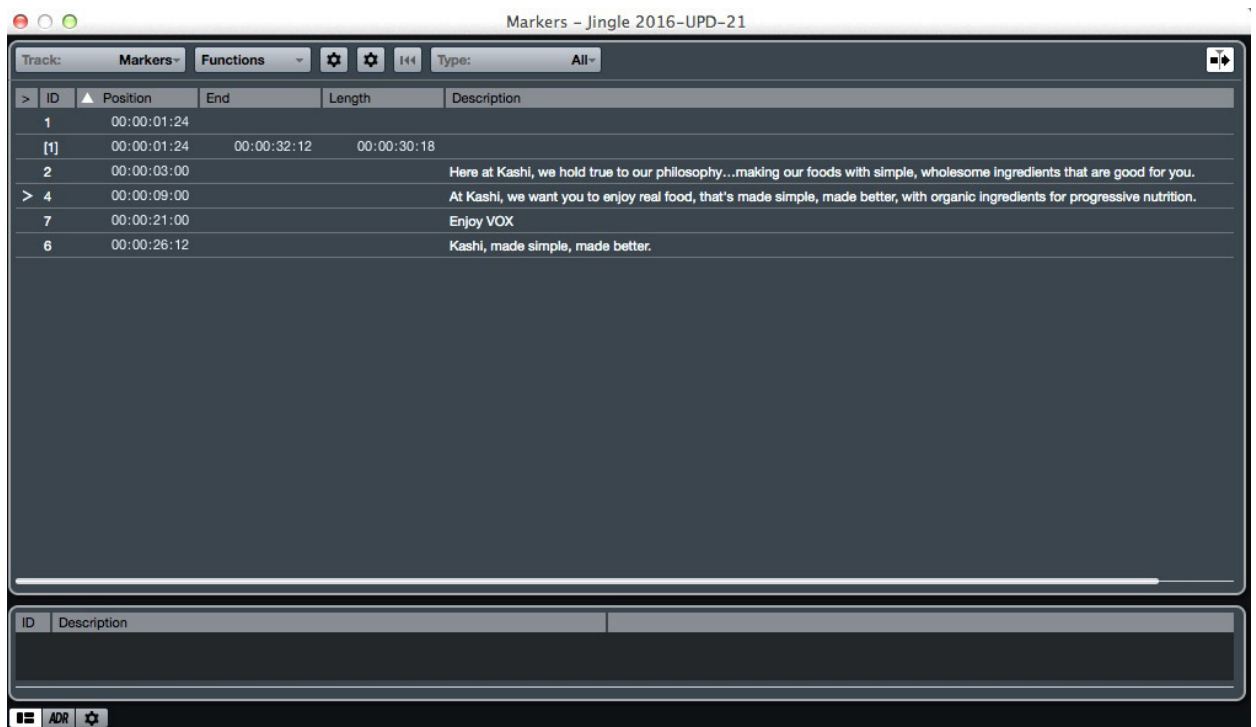

### 4.3.3 Mixing

One of the most challenging instruments to mix well is a drum kit. Finding the balance between all of the different sounds and the number of microphones is a challenging task. Using the internal mix console within the Studio Drummer library, I was able to modify the balance of the individual microphones as well as the amount of room mic level included in the drum mix. I also used a built-in compressor within Kontakt in order to flatten the dynamic range of the snare drum. This meant that there were less drastic changes in the volume of each snare drum hit.

Once I had achieved the desired balance of all the drum mics within the virtual instrument, I applied equalization and compression to the summed signal. I used the Neutron plugin created by Izotope. This plugin is designed like a channel strip on a traditional mixing console, where one has access to various audio processing tools, such as equalization and compression. For my drum track, I used both of these within Neutron to enhance the sound of the drum kit.

First I found a compression setting that would help control the dynamic range of the overall drum track. By setting the compressor attack to 1.4 milliseconds, considered a fast attack, I forced the almost immediate engagement of the compressor once the audio signal level exceeded the threshold. I set the ratio to 4:1, meaning that, for example, if the signal exceeded the threshold by 12 dB the compressor would output the signal at 3 dB above the threshold, therefore reducing the signal at a 4:1 ratio. On my drum bus, the resulting average gain reduction was around 7 dB, so I raised the output of my compressor by 7.5 dB. Often referred to as “make-up gain,” this allows you to raise the overall level of the signal after it has been affected by the compressor. By raising the make-up gain by about the same amount of gain reduction caused by the compressor, I was able to flatten the dynamic range of the drums so that all of the different sounds created by the drum kit were more balanced.

When applying EQ to the drum bus, I cut 3.2 dB at 1,200 Hz, with a wide enough bandwidth to affect a large swath of frequencies both above and below the 1,200 Hz cutoff (Figure 4.9). I also boosted at 3,151 Hz by 2.9 dB, with a similar size bandwidth. My goal was to add some brilliance to the drums by enhancing the high frequencies that would be created mostly by the cymbals and snare drum. The cut at 1,200 Hz was not just pleasing to the ear, but it is also common practice and often effective to cut frequencies some in order to amplify the effect of other frequencies that you are trying to boost. In this case, by cutting at 1,200 Hz it made the boost at 3,151 Hz even more effective. The boost in low frequencies was intended to give more low end to the kick drum.

Figure 4.9 – Drum Bus EQ - Neutron



When addressing the electric bass, I used the Neutron plugin primarily to apply the equalization I felt would help increase the brightness of the sound (Figure 4.10). When

I chose the bass instrument patch, I was happy with the warm, round, sound it had, but felt that it lacked some definition and was causing the overall mix to sound slightly “muddy.” By boosting 3,295 Hz by 3.1 dB and shaping the curve to affect frequencies starting at around 900 Hz and dropping off at about 10,000 Hz, I was able to bring out the higher frequency sounds in the bass, making it more clear and effective in the mix.

Figure 4.10 – Bass EQ - Neutron



When processing the lead vocal, I used two different takes from the recording session and panned one track left to about the 9 o'clock position and one to the right at the 3 o'clock position. I sent both tracks to a bus that I then applied dynamic and frequency processing on. Using Neutron once again, I applied drastic EQ changes and very harsh compression, but used the technique known as parallel processing. This technique is used to blend together an unprocessed signal with the processed version of the same signal. Although this is most commonly used with compression, it can also be used with EQ and other types of audio processing. For the lead vocal bus, I used both parallel compression and parallel equalization. Used as an insert effect, these settings would be too extreme and create undesirable results. By blending the unprocessed and processed versions together (the wet and dry signals), the desired balance and sound can be achieved. For the lead vocal bus, I used a balance of 71% dry signal and 29% processed signals. The result was a nice sounding lead vocal mix where the intelligibility of the lyrics was greatly enhanced.

As seen in figure 4.11, I made a drastic cut of 12.7 dB at 4,218 Hz and 7.2 dB at 924 Hz, the first with a smaller bandwidth and the second with a large enough bandwidth to affect frequencies as low as 250 Hz and as high as 4,000 Hz. I also heavily boosted (8.9 dB) 5,100 Hz a high shelf continued the high frequency boost. A shelf is a type of band shape for EQ that increases or decreases the level of all



frequencies above the cutoff frequency. This boost of high frequencies is part of what allows the lead vocal cut through the mix. One interesting feature within the Neutron EQ that I took advantage of the ability to use the nodes in “dynamic” mode. This allows you to set a threshold and either compress or expand the frequencies within this band when they exceed the chosen decibel value. In figure 4.11, the node numbered “7” is in dynamic compression mode. This allowed me to boost these high frequencies, while still maintaining control over them so that they did not become excessively abrasive when certain syllables containing very high frequency content were spoken.

The drastic amount of compression applied to this channel increases the volume of parts of the signal that are at a lower decibel level in the original recording (Figure 4.12). When I combined the processed and unprocessed signals and found the right balance of wet and dry signal, it made a significant difference in how the lead vocals were able to cut through the mix over the entire ensemble.

Figure 4.11 – Lead Vocal Parallel EQ - Neutron

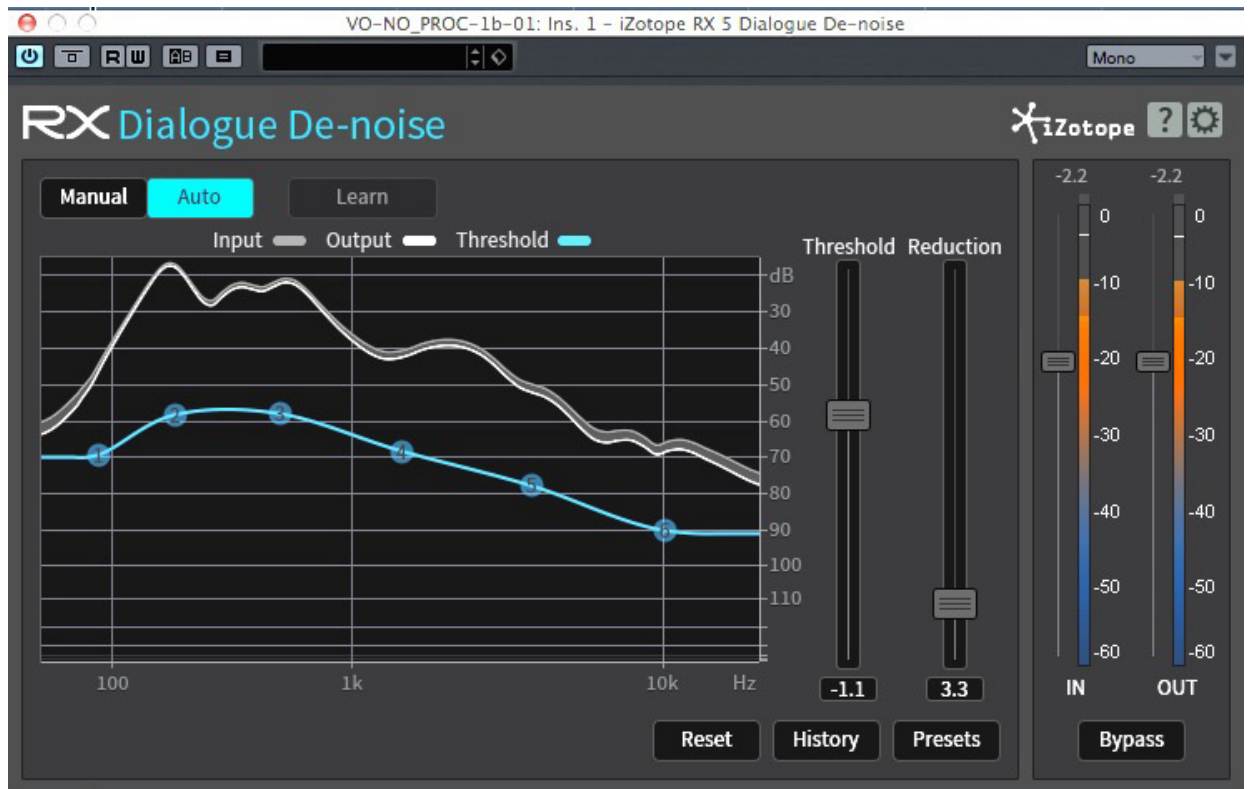

Figure 4.12 – Lead Vocal Parallel Compression - Neutron



The voice-over track proved to be one of the most difficult elements to manage in the overall mix of the jingle. During the recording, a considerable amount of sound from the headphones worn by the voice-over artist was captured by the microphone. Although I have encountered this issue on other projects, the amount of bleed captured by the microphone during this session was problematic. The first step I took to address this problem was to try and remove the background noise using another plugin by Izotope call RX Dialogue De-noise (Figure 4.13). I used the “Auto” setting and allowed the plugin to analyze the source signal and determine the appropriate shape of the reduction curve. The threshold and reduction sliders allow the user to adjust the point at which the reduction begins to take affect and how much reduction is applied.

Figure 4.13 – Voice-Over – Dialogue De-noise



After removing as much background noise as possible without negatively affecting the voice, I used the RX Audio Editor software, also by Izotope, in order address some loud clicks throughout the recording (Figure 4.14). These clicks were caused by the voice-over artist’s mouth and not as a result of recording errors, but were noticeable enough to be distracting to the listener. The RX Audio Editor allows the user to view audio in a spectrogram view rather than the more traditional waveform view. In a spectrogram, time is shown along the x axis, frequency along the y axis, and the volume of each frequency is displayed using color intensity. This allows for very detailed editing of undesirable events within an audio file.

Figure 4.14 – RX Audio Editor – Click Removal

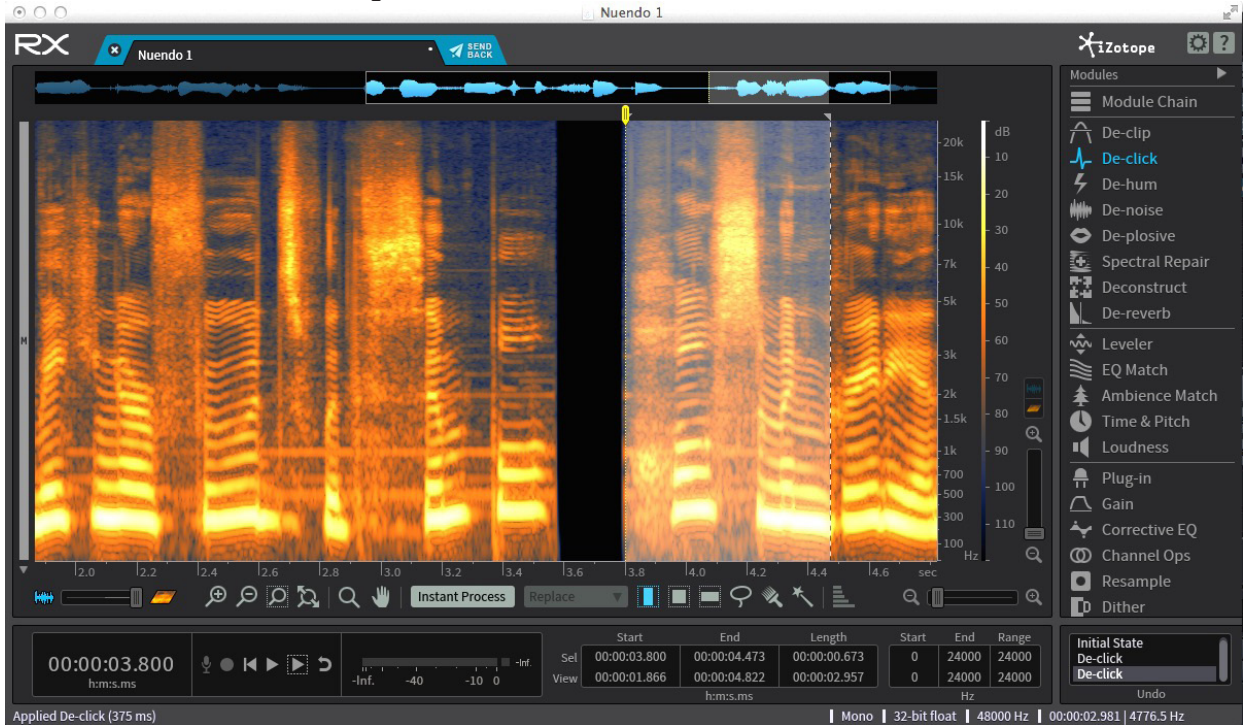

After resolving the noise and click problems throughout the voice-over track, I used Neutron to apply EQ and compression. First, I used the Waves RCompressor plugin to apply mild compression at a ratio of 2.12. I used the compressor to level out, or flatten, the dynamic range of the track, reducing the peaks between 4 and 6 dB, and using the gain to compensate with a boost of 5.8 dB. It should be noted that while editing the voice-over, I cut the audio into smaller regions to apply gain increases or decreases in order to reduce any large variances in volume. This was done using the visual representation of the waveform as a guide. The purpose of this is to decrease the number of decibels that exceed the threshold of the compressor, allowing for a more transparent manipulation of the dynamic range of the audio. Having too great of a range within the source audio can lead to excessive compression and less than transparent results.

The voice-over EQ focused on boosting the frequencies from about 1,500 Hz to 5,000 Hz, brightening the voice and benefiting intelligibility. I also cut 2.5 dB at 338 Hz to clear out some of the frequencies that we’re causing the voice to sound slightly “boxy,” referring to the way our voice is altered if we were to speak directly into a box. I enabled a shelf EQ with a cutoff frequency at 200 Hz with a relatively mild slope as the filter made its way to the bottom of the audible frequency range in humans, 20 Hz.

One of the more difficult mix issues I dealt with in the voice-over track was trying to reduce the level of high frequencies caused by sibilants in speech. Sibilants are sounds that can occur when pronouncing words with “s” “z” and “sh” sounds. Their frequency content lies between 2,000 and 10,000 Hz, depending on the person speaking. To reduce the volume of these specific frequencies in the voice-over track, I used the Nectar plugin, also created by Izotope (Figure 4.15). While this plugin provides a variety of audio processing tools, I chose to only use the De-Esser module. A De-Esser is a

frequency dependent compressor, normally used to reduce the level of frequencies above a certain cutoff frequency when the signal exceeds the chosen threshold. After some experimentation, I left the cutoff at 7,085 Hz and the threshold at -2.9 dB. This engaged the compressor at the moments when the sibilant consonants become harsh and distracting to the listener.

Figure 4.15 – Voice-Over De-Esser - Nectar





#### 4.4 CONCLUSION

When first tasked with this project, I found that by familiarizing myself with many different styles of 30 second radio commercials, I was able to quickly draw inspiration and begin to decide on my approach, making it easier to come up with an idea and a plan to execute the idea. When writing the voice-over, the most helpful materials came directly from the website of the company I chose to write a jingle for. The language and even the look of the company's website was an incredible resource for guidance and inspiration. The key words and style of writing used in the text found on the Kashi website was extremely useful when writing the voice-over script. In addition, the overall feel and mood that the company tries to promote in the language they use and the design of their website aided my decision making when it came to the genre of music, instrumentation, and even when choosing the voice-over artist.

The most difficult aspect I found was getting the right mix between the voice-over and music, so as to feature each one at the appropriate moments. The skill of setting a mood and delivering a message or call to action in such a short time is very challenging and one that I hope to improve at with future projects.



# APPENDIX A: ORCHESTRAL COMPOSITION: FULL SCORE

## Carnival of Shadows

v12b

Javier Albornoz

**Misterioso**  
♩ = 88

Flute I  
Flute II  
Flute III/Piccolo  
Oboe  
English Horn  
Clarinet I in B  
Clarinet II in B  
Bass Clarinet  
Bassoon I  
Bassoon II  
French Horn I  
French Horn II  
French Horn III  
French Horn IV  
Trumpet I in B  
Trumpet II in B  
Trumpet III in B  
Trombone I  
Trombone II  
Trombone III  
Tuba  
Percussion I  
Percussion II  
Vibes/Xylophone  
Timpani  
Harp  
Solo Violin  
Violin I  
Violin II  
Viola  
Cello  
Double Bass

1 2 3 4 5 6

**Flutes:** Fl I (mp, poco cresc, p), Fl II, Fl III/Pic.

**Woodwinds:** Ob, Eng Hn (poco cresc, mp), Cl I (poco cresc, mp, p), Cl II (p), Bs Cl (p), Bsn I (poco cresc, mp), Bsn II (poco cresc, mp).

**Horns:** Fn Hn I, II, III, IV (poco cresc).

**Brass:** Tpt I, II, III, Tb I, II, III, Tba.

**Percussion:** Perc (Tri.), Vbs/Xyl (poco cresc), Hrp (poco cresc).

**Strings:** Solo Vln (p, unis., dim), Vln I (p, unis., dim), Vln II, Vla (poco cresc, dim), Cel (poco cresc, dim), Dbl Bs (poco cresc, dim).

**Tempo/Performance:** Poco Rit. (measures 11-12).

7 8 9 10 11 12

Fl I

Fl II

Fl III/Pic

Ob

Eng Hn

Cl I

Cl II

Bs Cl

Bsn I

Bsn II

Fn Hn I

Fn Hn II

Fn Hn III

Fn Hn IV

Tpt I

Tpt II

Tpt III

Tb I

Tb II

Tb III

Tba

Perc

Vbs/Xyl

Solo Vln

Vln I

Vln II

Vla

Cel

Dbl Bs

I. to Sus. Cym.

B.D.

cresc

p

Flute

8<sup>va</sup>

Molto Rit.

Solo

mf

arco

13

14

15

16

17

A Tempo

Molto Rit.

Fl I I *mp* *cresc*

Fl II *mp* *cresc*

Fl III/Pic *mp* *cresc*

Ob

Eng Hn *mp* *cresc*

Cl I *mp* *cresc*

Cl II *mp* *cresc*

Bs Cl

Bsn I *mp* *cresc*

Bsn II *mp* *cresc*

Fa Hn I *mf* *cresc*

Fa Hn II *mp* *cresc*

Fa Hn III *mp* *cresc*

Fa Hn IV

Tpt I

Tpt II

Tpt III

Tb I *mp*

Tb II *mp*

Tb III

Tba

Perc B.D. *mp* *cresc*

Vbs/Xyl *mp* *cresc* to Xyl

Solo Vln *A Tempo* *Solo* *mf* *Molto Rit.*

Vln I *mp* *cresc*

Vln II *mp* *cresc*

Vla *mp* *cresc*

Cel *mp* *cresc*

Dbl Bs

18

19

20

21

22

23 Broadly Molto Rall. A Tempo Poco Rit. .... 5

Fl I I *mf* *cresc* *f* *mf* *dim*

Fl II *mf* *cresc* *f* *mf* *dim*

Fl III/Pic

Ob *mf* *cresc* *f* *mf* *dim*

Eng Hn *mf* *cresc* *f* *dim*

Cl I *mf* *cresc* *f*

Cl II *mf* *cresc* *f*

Bs Cl *mf* *f* *dim*

Bsn I *mf* *cresc* *f*

Bsn II *mf* *f* *dim*

Fn Hn I *mf* *cresc* *f* *dim*

Fn Hn II *mf* *cresc* *f* *dim*

Fn Hn III *mf* *cresc* *f* *mp*

Fn Hn IV *mf* *cresc* *f* *dim*

Tpt I *mf* *cresc* *f*

Tpt II *f* *dim*

Tpt III

Tb I *mf* *cresc* *f* *dim*

Tb II *mf* *cresc* *f* *dim*

Tb III *mf* *cresc* *f* *dim*

Tba *mf* *cresc* *f* *dim*

Perc S. Cym. *p* *f* L.v. I. to Flng. Cym.  
B.D. *p* *f* L.v.

Solo Vln *mf* *cresc* *f* *dim*

Vln I *mf* *cresc* *f*

Vln II *mf* *cresc* *f*

Vla *mf* *cresc* *f* *dim*

Cel *mf* *cresc* *f* *dim*

Dbl Bs *mf* *cresc* *f* *dim*

23 24 25 26 27 28 29

Meno Mosso

32 Moderato  
♩ = 100

Fl I

Fl II

Fl III/Pic

Ob

Eng Hn

Cl I

Cl II

Bs Cl

Bsn I

Bsn II

Fa Hn I

Fa Hn II

Fa Hn III

Fa Hn IV

Tpt I

Tpt II

Tpt III

Tb I

Tb II

Tb III

Tba

Perc

Vln I

Vln II

Vla

Cel

Dbl Bs

30

31

32

33

34

35

*Solo*

*mp*

*p subito*

*div.*

*pp subito*



Fl I I *p*

Fl II *p*

Fl III/Pic

Ob *p*

Eng Hn *p*

Cl I

Cl II *p*

Bs Cl

Bsn I

Bsn II

Fa Hn I

Fa Hn II *p*

Fa Hn III *p*

Fa Hn IV

Tpt I

Tpt II

Tpt III

Tb I

Tb II

Tb III

Tba

Perc *p*  
Finger Cymbals (thin)  
(strike sides against each other)

Xyl. *p*

Vbs/Xyl *p*

Hrp *p*  
(D C B E F G A)  
Gliss.

Vln I *mp* *espressivo*

Vln II *p* *div.*

Vla *p* *sempre legato* *div.*

Vla Div *p* *sempre legato* *div.*

Cel *p*

Dbl Bs *p*

36

37

38

39

40

41

Musical score for orchestral instruments, spanning measures 42 to 47. The score includes parts for Flutes I & II, Oboe, English Horn, Clarinets I & II, Bass Clarinet, Bassoons I & II, Horns I-IV, Trumpets I-III, Trombones I-III, Tuba, Percussion, Vibraphone/Xylophone, Harp, Violins I & II, Viola, Viola Divisi, Cello, and Double Bass. Performance markings include *poco cresc*, *mp*, and *port*.

Fl I *p*

Fl II *p*

Fl III/Pic

Ob *mp* *espressivo*

Eng Hn

Cl I

Cl II

Bs Cl

Bsn I *mp* *espressivo*

Bsn II

Fa Hn I

Fa Hn II

Fa Hn III

Fa Hn IV

Tpt I

Tpt II

Tpt III

Tb I

Tb II

Tb III

Tba

Perc *mp* *Fing. Cym.*

Vbs/Xyl

Hrp *mp* *8va* *10' C<sup>1</sup> E<sup>1</sup> F<sup>1</sup>*

Vln I *mp* *port.*

Vln II

Vla

Vla Dbl

Cel *mp* *cresc.*

Dbl Bs *cresc.*

Push Forward 56 Slightly Faster

The musical score is arranged in systems for various instruments. The top system includes Flute I & II, Flute III/Piccolo, Oboe, English Horn, Clarinet I & II, Bass Clarinet, Bassoon I & II, Horn I & II, Horn III & IV, Trumpet I & II & III, Trombone I & II & III, Tuba, Percussion, Vibraphone/Xylophone, and Harp. The bottom system includes Violin I & II, Viola, Viola Double Bass, Cello, and Double Bass. The score features dynamic markings such as *cresc*, *mp*, *mf*, and *mf* (arco). Performance instructions include *Push Forward*, *Slightly Faster*, *Picc.*, *Solo*, *unis.*, *cantando*, *div.*, *pizz.*, and *unis. (pizz.)*. Measure numbers 54 through 59 are indicated at the bottom of the page.

Fl I  
 Fl II  
 Fl III/Pic  
 Ob  
 Eng Hn  
 Cl I  
 Cl II  
 Bs Cl  
 Bsn I  
 Bsn II  
 Fh Hn I  
 Fh Hn II  
 Fh Hn III  
 Fh Hn IV  
 Tpt I  
 Tpt II  
 Tpt III  
 Tb I  
 Tb II  
 Tb III  
 Tba  
 Perc  
 Vbs/Xyl  
 Hrp  
 Vln I  
 Vln II  
 Vla  
 Vla Db  
 Cel  
 Dbl Bs

(Fing. Cym.)  
 mf  
 mp  
 (D C' B E' F G A)  
 mf  
 div.  
 mp  
 div.  
 mp  
 mp  
 mp

60 61 62 63 64 65



Fl I *poco cresc*

Fl II *poco cresc*

Fl III/Pic *poco cresc* to Flute

Ob *poco cresc*

Eng Hn *poco cresc*

Cl I *poco cresc*

Cl II *poco cresc*

Bs Cl *poco cresc*

Bsn I *poco cresc*

Bsn II *poco cresc* *mp* *cresc*

Fn Hn I

Fn Hn II *poco cresc*

Fn Hn III *poco cresc*

Fn Hn IV

Tpt I

Tpt II

Tpt III

Tb I

Tb II

Tb III

Tba

Perc

Vbs/Xyl

Hrp *8va* [D<sup>♯</sup> C<sup>♯</sup> E<sup>♯</sup> F<sup>♯</sup>] [D<sup>♯</sup> C<sup>♯</sup> B E F<sup>♯</sup> G A]

Vln I *port.* *poco cresc*

Vln II *poco cresc*

Vla *poco cresc*

Vla Div *poco cresc*

Cel *poco cresc*

Dbl Bs *poco cresc*

66 67 68 69 70 71

Fl I I *mp*

Fl II *mp*

Fl III/Pic Flute *mp*

Ob *mp*

Eng Hn *mp* *p*

Cl I *mp*

Cl II *mp* *p*

Bs Cl *p*

Bsn I *p*

Bsn II *p*

Fn Hn I *p*

Fn Hn II *p*

Fn Hn III *p*

Fn Hn IV *p*

Tpt I

Tpt II

Tpt III

Tb I

Tb II

Tb III

Tba

Perc (Fing. Cym.) *p* *pp* I. to Cr. Cym.

Vbs/Xyl *mp* *p* Gliss. *mp* **Molto Rall. ....**

Vln I *mp* *pizz.* *arco* *mp*

Vln II *mp* *pizz.* *div.* *arco* *p*

Vla *mp* *pizz.* *arco* *p*

Cel *mp* *div.* *(arco)*

Dbl Bs *mp* *(pizz.)* *arco* *p*

78 Allegro Moderato  
♩ = 115

Musical score for orchestra and strings. The score includes parts for Flutes I, II, III/Piccolo, Oboe, English Horn, Clarinets I and II, Bass Clarinet, Bassoons I and II, Horns I-IV, Trumpets I-III, Trombones I-III, Tuba, Percussion (Cr. Cym., B.D., Timp.), Violins I and II, Viola, Cello, and Double Bass. The score spans measures 78 to 83. Dynamics include *mf* and *f*. Performance instructions include *Cr. Cym.*, *B.D.*, *I. to Sus. Cym.*, *unis.*, and *arco*. The tempo is marked *Allegro Moderato* with a metronome marking of  $\text{♩} = 115$ .

78

79

80

81

82

83

Fl I I *mf*

Fl II *mf*

Fl III/Pic *mf*

Ob *mf*

Eng Hn *mf*

Cl I *mf*

Cl II *mf*

Bs Cl *mf*

Bsn I *mf*

Bsn II *mf*

Fn Hn I *mf*

Fn Hn II *mf*

Fn Hn III *mf*

Fn Hn IV *mf*

Tpt I *mf*

Tpt II *mf*

Tpt III *mf*

Tb I *mf*

Tb II *mf*

Tb III *mf*

Tba *mf*

Perc *mf*

Timp *mf*

Vln I *mf*

Vln II *mf*

Vla *mf*

Cel *mf*

Dbl Bs *mf*

Musical score for orchestra, measures 90-96. The score includes parts for Flutes I and II, Flute III/Piccolo, Oboe, English Horn, Clarinets I and II, Bass Clarinet, Bassoons I and II, Horns I, II, III, and IV, Trumpets I, II, and III, Trombones I, II, and III, Tuba, Percussion, Timpani, Violins I and II, Viola, Cello, and Double Bass. The score features various musical notations including dynamics (crescendo, *p*), articulation (div.), and performance instructions (to *Picc.*). The key signature is one sharp (F#) and the time signature is 4/4.

90 91 92 93 94 95 96



Fl I *mf*  
 Fl II *mf*  
 Fl III/Pic. *mf*  
 Ob *mf*  
 Eng Hn  
 Cl I *mf*  
 Cl II *mf*  
 Bs Cl *f*  
 Bsn I *f*  
 Bsn II *f*  
 Fh Hn I *mf*  
 Fh Hn II *mf*  
 Fh Hn III *p*  
 Fh Hn IV *p*  
 Tpt I *f*  
 Tpt II *f*  
 Tpt III *p*  
 Tb I *f*  
 Tb II *p*  
 Tb III *f*  
 Tba *mf*  
 Perc (B.D.) *f*  
 Timp *f*  
 Vln I *f*  
 Vln II *f*  
 Vla *f*  
 Cel *f*  
 Dbl Bs *f*

This page contains the musical score for measures 101 through 104. The score is arranged in a standard orchestral format with the following parts from top to bottom:

- Flutes I, II, and III/Piccolo
- Oboe
- English Horn
- Clarinets I and II
- Bass Clarinet
- Bassoons I and II
- Horns I, II, III, and IV
- Trumpets I, II, and III
- Trombones I, II, and III
- Tuba
- Percussion
- Timpani
- Violins I and II
- Viola
- Cello
- Double Bass

Measure 101 features a complex rhythmic pattern with triplets and sixteenth notes in the woodwinds and strings. Measure 102 continues this pattern with dynamic markings of *f* and *p*. Measure 103 shows a transition with a *cresc.* marking and a *sfzp* dynamic. Measure 104 concludes the section with a *mf* dynamic and a *cresc.* marking. The score includes various musical notations such as slurs, accents, and dynamic markings.

101

102

103

104

This page contains the musical score for measures 105 through 108 of a section titled "Furioso". The score is arranged for a full orchestra and includes the following parts:

- Flutes:** Fl I, Fl II, Fl III/Pic.
- Woodwinds:** Oboe (Ob), English Horn (Eng Hn), Clarinet I (Cl I), Clarinet II (Cl II), Bass Clarinet (Bs Cl), Bassoon I (Bsn I), Bassoon II (Bsn II).
- Horns:** French Horn I (Fn Hn I), French Horn II (Fn Hn II), French Horn III (Fn Hn III), French Horn IV (Fn Hn IV).
- Trumpets:** Tpt I, Tpt II, Tpt III.
- Trombones:** Tbn I, Tbn II, Tbn III, Tuba (Tba).
- Percussion:** Percussion (Perc), Vibraphone/Xylophone (Vbs/Xyl), Timpani (Timp).
- Strings:** Violin I (Vln I), Violin II (Vln II), Viola (Vla), Cello (Cel), Double Bass (Dbl Bs).

The score is marked with a dynamic of *f* (forte) throughout. Measure 105 begins with a *f* dynamic. Measure 106 features a *f* dynamic. Measure 107 includes dynamic markings of *sfz* (sforzando) and *f*. Measure 108 includes dynamic markings of *p* (piano) and *f*. The tempo is marked "Furioso".

This page contains the musical score for measures 109 through 112. The score is arranged in a standard orchestral format with multiple staves for each instrument family. The instruments listed on the left are: Flute I (Fl I), Flute II (Fl II), Flute III/Piccolo (Fl III/Pic), Oboe (Ob), English Horn (Eng Hn), Clarinet I (Cl I), Clarinet II (Cl II), Bass Clarinet (Bs Cl), Bassoon I (Bsn I), Bassoon II (Bsn II), Horn I (Fn Hn I), Horn II (Fn Hn II), Horn III (Fn Hn III), Horn IV (Fn Hn IV), Trumpet I (Tpt I), Trumpet II (Tpt II), Trumpet III (Tpt III), Trombone I (Tb I), Trombone II (Tb II), Trombone III (Tb III), Tuba (Tba), Percussion (Perc), Vibraphone/Xylophone (Vbs/Xyl), Timpani (Timp), Violin I (Vln I), Violin II (Vln II), Viola (Via), Cello (Cel), and Double Bass (Dbi Bs). The score includes various musical notations such as notes, rests, dynamics (e.g., *mf*, *cresc*, *ff*, *sfzp*, *f*, *p*, *mp*), and articulation marks. Measure numbers 109, 110, 111, and 112 are indicated at the bottom of the page.

109

110

111

112

Fl I

Fl II

Fl III/Pic

Ob

Eng Hn

Cl I

Cl II

Bs Cl

Bsn I

Bsn II

Fn Hn I

Fn Hn II

Fn Hn III

Fn Hn IV

Tpt I

Tpt II

Tpt III

Tb I

Tb II

Tb III

Tba

Perc

Timp

Vln I

Vln II

Vla

Cel

Dbl Bs

113

114

115

116

*f*

*mf*

*p*

*sfz*

*cresc.*

*tr.*

*un.*

*espressivo*

B to C  
E to F

(F, C)

This page contains the musical score for measures 117 through 121. The score is written for a full orchestra and includes the following parts: Flute I (Fl I), Flute II (Fl II), Flute III/Piccolo (Fl III/Pic), Oboe (Ob), English Horn (Eng Hn), Clarinet I (Cl I), Clarinet II (Cl II), Bass Clarinet (Bs Cl), Bassoon I (Bsn I), Bassoon II (Bsn II), Horn I (Fn Hn I), Horn II (Fn Hn II), Horn III (Fn Hn III), Horn IV (Fn Hn IV), Trumpet I (Tpt I), Trumpet II (Tpt II), Trumpet III (Tpt III), Trombone I (Tb I), Trombone II (Tb II), Trombone III (Tb III), Tuba (Tba), Percussion (Perc), Timpani (Timp), Violin I (Vln I), Violin II (Vln II), Viola (Vla), Cello (Cel), and Double Bass (Dbl Bs). The score is in a key signature of two flats (B-flat and E-flat) and a 3/4 time signature. The music features complex rhythmic patterns, including triplets and sixteenth-note runs. Dynamics include *f* (forte) and *cresc.* (crescendo). The page is numbered 117, 118, 119, 120, and 121 at the bottom.



Fl I  
Fl II  
Fl III/Pic  
Ob  
Eng Hn  
Cl I  
Cl II  
Bs Cl  
Bsn I  
Bsn II  
Fn Hn I  
Fn Hn II  
Fn Hn III  
Fn Hn IV  
Tpt I  
Tpt II  
Tpt III  
Tb I  
Tb II  
Tb III  
Tba  
Perc  
Timp  
Vln I  
Vln II  
Vla  
Cel  
Dbl Bs

122 123 124 125 126 127

# APPENDIX B: CUES FOR DRAMATIC SHORT FILM: FULL SCORE

## Rankling

MX01/02 - Opening Title/The Proposition

Javier Albornoz

TC START: 00.00.01.10

♩ = 83

Americana, Dark, Foreboding

Banjo

Banjo FX

Steel String Guitar

Guitar FX

Solo Violin I

Solo Violin II

Synth Pad I

Synth Pad II

Sub Kick

Solo Contrabass

Folk Playing Style

Non-Arp.

*mp*

*mf*

*dim*

*pppp*

*p*

\*Notes Trigger Unpitched Synth Effect - Tassman VST

1 2 3 4 5 6 7 8

Bjo

SynPad I

9 10 11 12 13 14

Bjo

SynPad I

"I want him gone!" "...you do it yourself."

15 16 17 18 19 20

Bjo

SynPad I

21 22 23 24 25 26

Bjo

SynPad I

27 28 29 30 31 32

Bjo

SynPad I

l.v. to End w/ Fade Out

33 34 35 36 37

# Rankling

MX07/08 - The Arrest/End Title and Credits

Javier Albornoz

TC START: 00.07.46.10

Americana, Dark, Foreboding

♩ = 55 (Slight Variations in Tempo Throughout Are Reflected in Tempo Map)

Banjo I

Banjo II

Banjo FX

Steel String Guitar

Guitar FX

Solo Violin I

Solo Violin II

Synth Pad I

Synth Pad II

Sub Kick

Solo Contrabass

1 2 3 4

Bjo I

SynPad I

SynPad II

5 6 7 8

Bjo I

SynPad I

SynPad II

Solo Cbs

9 10 11 12 13

Bjo FX

Gtr

Gtr FX

S. Vln I

SynPad I

SubKick

Solo Cbs

\*Heavily Effected Guitar Sound Design

14 15 16 17

Bjo I { 6/4  
 Bjo FX { 6/4  
 Gtr { 6/4  
 S. Vln I 6/4  
 SynPad I { 6/4  
 SubKick 6/4  
 Solo Cbs 6/4

18
19
20

Bjo I { 6/4  
 Bjo FX { 6/4  
 Gtr { 6/4  
 S. Vln I 6/4  
 S. Vln II 6/4  
 SynPad I { 6/4  
 SubKick 6/4  
 Solo Cbs 6/4

21
22
23



24 25 26

27 28

Bjo I  
 Bjo II  
 Gtr  
 Gtr FX  
 SynPad I  
 SubKick  
 Solo Cbs

29                      30                      31                      32

Bjo I  
 Bjo II  
 Gtr  
 Gtr FX  
 SynPad I  
 SubKick  
 Solo Cbs

33                      34                      35                      36                      37

# APPENDIX C: COMMERCIAL UNDERS- CORE: FULL SCORE

## *The Canterbury Gardens*

### Commercial Underscore

Javier Albornoz

With A Sense of Intrigue  
♩ = 106

Flute

Oboe

English Horn 1 & 2

Bassoon

French Horns 1 & 2

French Horns 3 & 4

Harp

Piano

Violin I

Violin II

Viola

Cello

Double Bass

*p*

*p*

1

2

3

4

Musical score for measures 5 through 8. The score includes the following instruments and parts:

- Fl (Flute)
- Ob 1&2 (Oboe 1 and 2)
- EHn 1&2 (English Horn 1 and 2)
- Bsn (Bassoon)
- FnHn 1&2 (French Horn 1 and 2)
- Fn Hn 3&4 (French Horn 3 and 4)
- Hrp (Harp)
- Pno (Piano)
- Vln I (Violin I)
- Vln II (Violin II)
- Vla (Viola)
- Cel (Cello)
- Dbl Bs (Double Bass)

The score shows rests for most instruments in measures 5, 6, and 7. In measure 8, the Piano part features a melodic line in the right hand and a rhythmic accompaniment in the left hand. The Cello part has a long note in measure 8. The Double Bass part has a long note in measure 8.

5

6

7

8

Fl  
 Ob 1&2  
 EHn 1&2  
 Bsn  
 F#Hn 1&2  
 F#Hn 3&4  
 Hrp  
 Pno  
 Vln I  
 Vln II  
 Vla  
 Cel  
 Dbl Bs

*p*  
*al*  
*p*  
*p*  
*p*  
*p*  
*p*  
*pizz.*  
*p*  
*legato*

9 10 11 12 13 14 15

Fl

Ob 1&2

EHn 1&2  
*mp*

Bsn

FnHn 1&2

Fn Hn 3&4

Hrp

Pno

Vln I  
*dim*

Vln II

Vla  
*p*

Cel  
*p*

DbI Bs

16

17

18

19

20

21



Fl *mp*  
 Ob 1&2 *mp* a2  
 EHn 1&2 *mp* a1  
 Bsn *mp*  
 FnHn 1&2  
 Fn Hn 3&4  
 Hrp *mp*  
 Pno *mp*  
 Solo Vln *mp* div.  
 Vln I *mp* div.  
 Vln II  
 Vla *mp*  
 Cel *mp* div.  
 Cel II *mp* div.  
 Dbl Bs *mp*

22 23 24 25 26 27

Fl  
 Ob 1&2  
 EHn 1&2  
 Bsn  
 FnHn 1&2  
 Fn Hn 3&4  
 Hrp  
 Pno  
 Solo Vln  
 Vln I  
 Vln II  
 Vla  
 Cel  
 Cel II  
 Dbl Bs  
 Dbl Bs II

a2  
 mp  
 mf  
 mf  
 mf  
 mf  
 mf  
 f  
 f  
 div.  
 pizz.  
 mf  
 div.  
 arco  
 mf

28      29      30      31      32      33

Fl  
 Ob 1&2  
 EHn 1&2  
 Bsn  
 F#Hn 1&2  
 F#Hn 3&4  
 Hrp  
 Pno  
 Vln I  
 Vln II  
 Vla div.  
 Vla II div.  
 Cel  
 Cel II  
 Dbl Bs  
 Dbl Bs II

Musical score for measures 34-39. The score includes parts for Flute (Fl), Oboe (Ob 1&2), English Horn (EHn 1&2), Bassoon (Bsn), French Horn (F#Hn 1&2, F#Hn 3&4), Harp (Hrp), Piano (Pno), Violin I (Vln I), Violin II (Vln II), Viola (Vla I, Vla II), Cello (Cel I, Cel II), Double Bass (Dbl Bs I, Dbl Bs II), and Double Bass II (Dbl Bs II). The score features various musical notations including rests, notes, slurs, and dynamic markings such as *cresc* and *div.*.

34

35

36

37

38

39

Fl  
 Ob 1&2  
 EHn 1&2  
 Bsn  
 FnHn 1&2  
 Fn Hn 3&4  
 Hrp  
 Pno  
 Solo Vln I  
 Solo Vln II  
 Vln I  
 Vln II  
 Vla  
 Cel  
 Cel II  
 Dbl Bs  
 Dbl Bs II

*mf*  
*f*  
*simile*  
*f*  
*unis.*  
*unis.*  
*poco cresc*

40 41 42 43 44 45

The musical score is arranged in a standard orchestral format. The instruments and their parts are as follows:

- Flute (Fl):** Five staves, all showing rests.
- Oboe (Ob):** Two staves, both showing rests.
- English Horn (EHn):** Two staves, both showing rests.
- Bassoon (Bsn):** One staff, showing rests.
- French Horns (Fn Hn):** Four staves. The first two (1&2) play a melodic line starting on page 47 with a forte (*ff*) dynamic and crescendo (*cresc*). The last two (3&4) play a sustained harmonic accompaniment, also with a crescendo.
- Harp (Hrp):** Two staves, both showing rests.
- Piano (Pno):** Two staves. The right hand is silent. The left hand plays a rhythmic eighth-note pattern that crescendos.
- Solo Violin (Solo Vln):** One staff, playing a rhythmic eighth-note pattern that crescendos.
- Violin I (Vln I):** One staff, playing a sustained chord with a tremolo effect, marked *div.* and *1/2 of Section Trem. to End*.
- Violin II (Vln II):** One staff, playing a sustained chord with a tremolo effect, marked *div.* and *1/2 of Section Trem. to End*, then *unis.* and *cresc*.
- Viola (Vla):** One staff, playing a sustained chord with a tremolo effect, marked *cresc*.
- Cello (Cel):** One staff, playing a sustained chord with a tremolo effect, marked *cresc*.
- Cello II (Cel II):** One staff, playing a sustained chord with a tremolo effect, marked *cresc*.
- Double Bass I (Dbl Bs):** One staff, playing a sustained chord with a tremolo effect, marked *cresc*.
- Double Bass II (Dbl Bs II):** One staff, playing a sustained chord with a tremolo effect, marked *cresc*.

46

47

48

49

50

Fl  
 Ob 1&2  
 EHn 1&2  
 Bsn  
 F#Hn 1&2  
 F#Hn 3&4  
 Hrp  
 Pno  
 Solo Vin  
 Vln I  
 Vln II  
 Vla  
 Cel  
 Cel II  
 Dbl Bs

*sfzp* *f*  
*sfzp* *f*  
*sfzp* *f*  
*sfzp* *f*  
*sfzp* *f*  
*sfzp* *f*  
*sfzp* *f*  
*sfzp* *f*  
*sfzp* *f*  
*sfzp* *f*  
*sfzp* *f*  
*sfzp* *f*  
*sfzp* *f*

div. 1/2 of Section Trem.  
 div. 1/2 of Section Trem.  
 div. 1/2 of Section Trem.  
 div. 1/2 of Section Trem.

51 52 53

# APPENDIX D: RADIO JINGLE: FULL SCORE

## MTC746/796-Jingle

### Kashi Jingle

Javier Albornoz

♩ = 100

Violin/Voice (V.O. 1) Clicks Vln

Cello Clicks

Acoustic Guitar Clicks E E E (or similar arpeggio pattern)

Piano Clicks Clicks

Bass Clicks

Drums Clicks

The musical score is written in 4/4 time with a key signature of three sharps (F#, C#, G#). It consists of seven staves: Violin/Voice (V.O. 1), Cello, Acoustic Guitar, Piano, Bass, and Drums. The first measure of each staff contains a series of four 'x' marks, representing a rhythmic pattern of four eighth notes. The second, third, and fourth measures of the Acoustic Guitar staff contain a sustained 'E' chord with an arpeggiated pattern of eighth notes. The other instruments have rests in these measures. The tempo is marked as quarter note = 100.



Vln/Vox 5 (V.O. 2) (V.O. 3)

Cel

Ac. Gtr E G (sim) D E

Pn

Bs

Dr \*Fill

Vln/Vox 9 En joy Real Food (V.O. 4)

Cel Vln+Vox

Ac. Gtr E G D E

Pn G D E

Bs

Dr

2

Vln/Vox 13

Musical score for Vln/Vox, Cel, Ac. Gtr, Pn, Bs, and Dr. The score is in E major (three sharps) and 4/4 time. It consists of two measures. The Vln/Vox part has a whole rest in both measures. The Cel part has a whole rest in both measures. The Ac. Gtr part has a triplet of eighth notes (E, A/E, E) in the first measure and a quarter note (E) in the second measure. The Pn part has a triplet of chords (E, A/E, E) in the first measure and a quarter note (E) in the second measure. The Bs part has a triplet of eighth notes (E, A/E, E) in the first measure and a quarter note (E) in the second measure. The Dr part has a triplet of eighth notes (E, A/E, E) in the first measure and a quarter note (E) in the second measure.

# ABOUT THE AUTHOR

Having marveled at the music of great film composers, **Javier Albornoz** began to study the clarinet and saxophone as well as experimenting with recording and MIDI technology at nine years of age. He found the enjoyment of creating music so fulfilling that it sparked the desire in him to pursue a career in the music field early on.

Javier has a bachelor's degree from Berklee College of Music and a Master's degree from the University of Miami and has worked in audio post-production for over a decade. He is also a proud member of The Alhambra Orchestra in Coral Gables, serving as assistant principal clarinetist and writing commissioned orchestral works premiered in 2015 and 2016.

In recent years, Javier has contributed dozens of works to a production music library, while also working with several Malaysian animation studios in the production of television pilots that have been featured at the Asian Animation Summit, MIPCOM, and other international conferences and markets.

Also versed in audio post-production and sound design, Javier has taught in the graduate music technology department at the University of Miami's Frost School of Music and works with students in the Animation and Game Development department and composition students at New World School of the Arts and Miami Dade College.

